



# Copper Brass Bronze Design Handbook

## Architectural Applications

**Cu**

**Copper Development  
Association Inc.**

Copper Alliance

**Cu**

**Canadian Copper & Brass  
Development Association**

Copper Alliance

# TABLE OF CONTENTS

<b>I. INTRODUCTION .....</b>	<b>3</b>		
COPPER AND ITS ALLOYS.....	3	Table 6. Comparison between Brown & Sharp (B&S) and U.S. Standard Gauge (USSG) for Sheet Metals.....	31
<b>II. IDENTIFYING COPPER ALLOYS .....</b>	<b>5</b>	Table 7. Color Matches with Various Fixture Forms of Compatible Copper Alloys.....	31
COPPER ALLOY FAMILIES.....	6	Table 8. Characteristics of Common Fastener Alloys .....	32
Coppers.....	6	Table 9. Metallurgical Joining Processes and Their Uses .....	33
Brasses .....	7	Table 10. Suitability of Copper Metals for Metallurgical Joining Processes..	33
Bronzes .....	7	Table 11. Minimum Web Thicknesses Based on Overall Extrusion Cross-sectional Size .....	34
Copper Nickels.....	8	Table 12. Straightness Tolerances for Copper Tube, ASTM B251 .....	34
Nickel Silvers .....	8	Table 13. Permissible Corner Radii for Commercial Square Tubing, ASTM B251.....	34
INTERNATIONAL DESIGNATIONS.....	8	Table 14. Thermal Expansion/Contraction Coefficients for Selected Copper Metals.....	35
<b>III. PHYSICAL PROPERTIES AND APPEARANCE .....</b>	<b>9</b>	Table 15. BHMA and U.S. Finishes for Brass and Bronze Hardware.....	35
ANTIMICROBIAL PROPERTY OF COPPER .....	9	Table 16. Standard Designations for Mechanical Finishes .....	36
Effectiveness .....	9	Table 17. Standard Designations for Chemical Finishes .....	37
Clinical Trials .....	10	Table 18. Standard Designations for Laminated Finishes .....	37
Considerations .....	11		
GENERAL PROPERTIES AND COLOR .....	11	<b>VI. FINISHES .....</b>	<b>38</b>
Color Matching.....	12	MECHANICAL FINISHES .....	38
Corrosion Resistance .....	12	As-fabricated .....	38
<b>IV. FABRICATION METHODS.....</b>	<b>15</b>	Polished and Buffed .....	39
FORMING .....	15	Directionally Textured.....	39
Bending.....	15	Nondirectional Textured.....	39
Brake Forming .....	15	Patterned .....	40
Roll Forming.....	16	CHEMICAL FINISHES.....	40
Extrusion.....	16	Conversion Coatings .....	40
Casting .....	16	Patinas.....	41
Forging.....	16	Oxide or statuary bronze .....	42
Stamping .....	17	PROTECTIVE COATINGS.....	42
Hydroforming.....	17	Clear Organic Coatings .....	42
Spinning.....	17	Oils and Waxes.....	43
Laminating .....	17	Vitrous Enamels .....	44
Explosive Forming.....	17	Metallic .....	44
JOINING.....	18	Heat Treatment .....	44
Seamed Joints .....	18	LAMINATED FINISHES .....	44
Mechanical Fasteners .....	18	STANDARD FINISH DESIGNATIONS .....	44
Metallurgical Joining Processes .....	18	<b>VII. MAINTENANCE .....</b>	<b>46</b>
<b>V. DESIGN AND INSTALLATION GUIDELINES .....</b>	<b>20</b>	PATINAS .....	47
SHEET, STRIP AND PLATE.....	20	CLEAR COATINGS .....	47
EXTRUSIONS.....	21	STATUARY FINISHES .....	47
TUBE .....	21	SHINY SURFACES .....	47
THERMAL EXPANSION AND CONTRACTION.....	25	PAINT REMOVAL.....	47
PROTECTION .....	26	<b>VIII. CONCLUSION.....</b>	<b>48</b>
<b>TABLES .....</b>	<b>27</b>	<b>ENDNOTES .....</b>	<b>49</b>
Table 1. Compositions, Historic Trade Names, Colors, Properties and Specifications for Selected Copper Alloys .....	27	<b>REFERENCES.....</b>	<b>50</b>
Table 2. Tensile and Yield Strengths of Cold-rolled Copper by Temper, ASTM B370 .....	29	<b>FIGURE / PHOTO CREDITS.....</b>	<b>51</b>
Table 3. Examples of Temper Designations for Copper Alloys, ASTM B601 .....	29		
Table 4. Typical Tensile Properties of Selected Commercial Copper Alloys in Various Tempers Compared with Steels and Aluminum.....	30		
Table 5. Typical Dimensions of Copper Sheet and Strip.....	30		

# I. INTRODUCTION

## COPPER AND ITS ALLOYS

Copper and its alloys are arguably the most attractive, most versatile and, importantly, the most environmentally compatible group of materials for architectural applications. Old, yet new – seasoned, yet fresh – copper and its alloys have served architecture and architects gracefully for millennia, yet their application can be as novel as the human imagination permits.



**Figure I-1.** Copper is man's oldest metal. For some 10,000 years, it has served thousands of purposes: from powering our planet, helping to heat and cool and cook, providing a healthful pathway for the water we drink, to protecting against corrosion and lending elegance to some of the world's most beautiful architecture.

### Why consider copper alloys?

This handbook offers many reasons, perhaps the most salient of which is *design freedom*. Few materials, and certainly no other metals, offer the architect so many options to create designs as stunning as they are enduring. Copper is inherently beautiful. Whether new-penny bright or transformed to an ageless patina, the copper metals are universally eye-pleasing. The copper family is also versatile, not simply in its many colors, but also in the diversity of surface textures and the extensive variety of available product forms.



**Figure I-2.** Copper is the most recycled of all engineering metals. Its value to mankind is repeatedly recast from one useful product to another.

**This door (pictured right) is one of a pair fabricated in silicon bronze by Wiemann Metalcraft to a custom design by JT Architects.**



Copper alloys are malleable, easy to adapt to even ambitious shapes. They are light in weight – especially when compared with many other roofing and cladding materials – and simple to either mechanically or metallurgically join. They are durable, chemically and dimensionally stable, yet can be tinted, oxidized and altered in countless ways. Their unsurpassed thermal and electrical conductivities are well known and widely utilized. **Table 1** provides a look at the remarkable physical and mechanical properties of several copper alloys used architecturally.

Perhaps, even more important is the intrinsic ability of copper and many of its alloys to kill harmful bacteria rapidly and completely (See **Chapter III**, page 9).<sup>1</sup> This antimicrobial property promises new and important applications for the copper metals in healthcare facilities and a wide range of other buildings where protecting human health is a concern. Alloys marked with a (\*) in **Table 1** are registered with the U.S. Environmental Protection Agency as an Antimicrobial Copper Alloy.



**Figure I-3.** Antimicrobial Copper sink and faucet installed at the Ronald McDonald House of Charleston, South Carolina. Healthcare facilities around the world are recognizing products made from EPA-registered Antimicrobial Copper alloys continuously kill bacteria that cause infections. The sink is made by Elkay Commercial Products and the faucet by Rocky Mountain Hardware.

And, finally, there is copper's harmony with the environment. Easily recycled, often upcycled to higher-valued products and never intentionally discarded, the metal is routinely used again and again, economically and with high energy efficiency. It is benign to nature, necessary to the health of all creatures and a worthy material to create sustainable buildings and help achieve LEED<sup>2</sup> and other "green" building certifications.

Copper – an ancient metal that welcomes new ideas.



**Figure I-4.** a) Heat-treated and chemically weathered panels at the National Museum of the American Indian, Washington, D.C. b) Ornate flashing, finials and cresting on New York's Engine Company 31, naturally weathering since 1896, New York, New York. c) Prepatinated copper facade on Penn State's School of Architecture and Landscape Architecture, State College, Pennsylvania.

---

## II. IDENTIFYING COPPER ALLOYS

---

Copper alloys are identified by numerical designations and often by historic names. Numerical designations avoid any misinterpretations. This handbook presents both numerical designations and historic names where they exist.

The Unified Numbering System (UNS) for metals and alloys is widely used in North America. Based on chemical composition, it arranges alloys into groups by major alloying elements. For example, brasses are copper alloys with zinc as the principal addition. Bronzes, once exclusively copper-tin alloys, now also include subgroups based on silicon, aluminum and manganese. A number of these alloys exhibit properties (high strength, exceptional tarnish resistance) that invite their architectural use.

UNS designations for copper metals consist of the letter "C" followed by five numerical digits and are managed by the Copper Development Association (CDA). Wrought metals (*i.e.*, those supplied as rolled, drawn, extruded or forged products) carry UNS numbers ranging from C10100 to C79999, while cast alloys are numbered from C80000 to C99999. The UNS designations echo an earlier but still popular three-digit system of "CDA numbers." UNS designations are simply CDA numbers followed by two more digits, which are two zeros for most alloys. Thus, Architectural Bronze, once identified as CDA 385, is now referred to as UNS C38500.

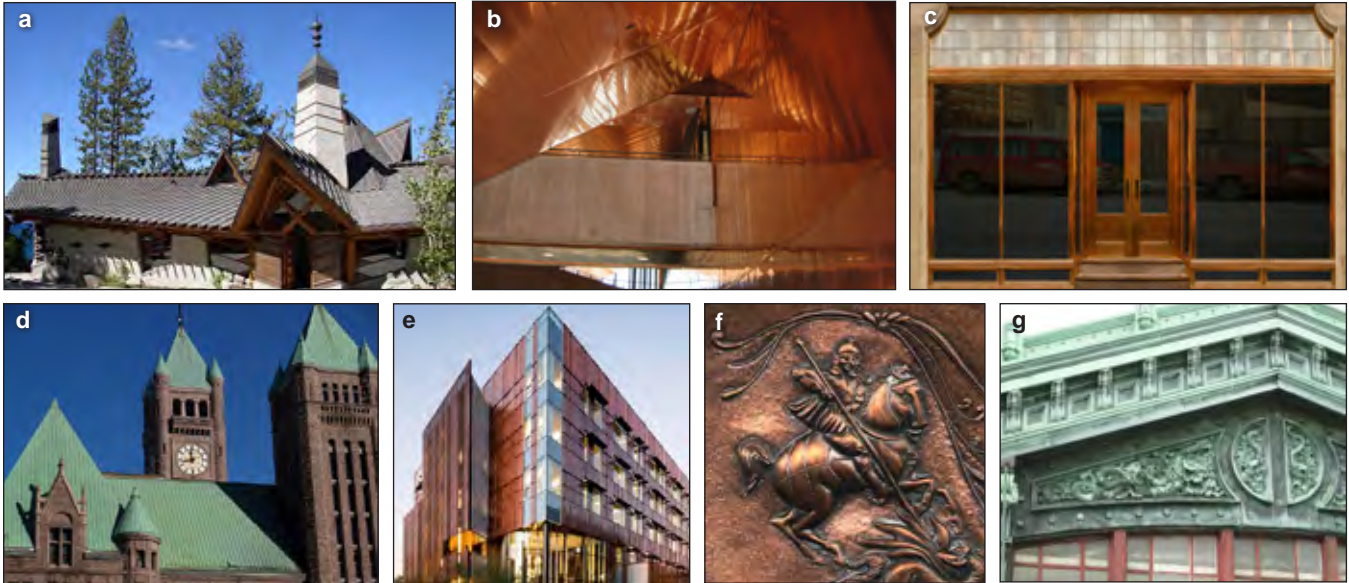
There are nearly 800 UNS copper alloys. **Table 1** lists those most commonly used in architecture. They are divided into five principal families: Coppers, Brasses, Bronzes, Copper Nickels and Nickel Silvers. Along with their significant physical and mechanical properties, chemical compositions, applicable standards and color information, the table cites the most popular historic trade name for the alloy.

Some historic trade names for copper alloys contain percentages or simply numbers. These refer to one or more of an alloy's constituents. Since alloys were developed in different industries, it is not surprising that the terminology varies. Thus, among brasses, such as C26000 "Cartridge Brass, 70%," the percentage identifies the copper content. Among copper nickels, such as C70600 "Copper Nickel, 10%," the percentage refers to nickel content, while in nickel silvers, such as C74500 "Nickel Silver, 65-10," the numbers refer to the percentage of copper and nickel present, respectively. Designations for casting alloys, such as C83600 "Ounce Metal, 85-5-5-5," may seem arcane, but simply spell out the composition: *viz.*, 85% copper, 5% tin, 5% lead, 5% zinc. This alloy is sometimes referred to as "Composition Bronze."

The architectural term, "*Statuary Bronze*," does not refer to a specific alloy but instead describes the range of naturally weathered or chemically oxidized brown-to-black surfaces that can be formed on many copper metals. Similarly, patinas — whether natural or synthetic — are sometimes referred to as "*Green Bronze*."

---

**Chemical and Mechanical finishes create a nearly infinite range of colors and textures on copper alloys.**



**Figure II-1.** Evolving through the centuries, Copper's architectural role now spans roofing, wall cladding and decorative applications; both outside and inside the building envelope. **a)** Lake Tahoe, Nevada, home with angular styling. Note the mix of copper shingles, standing seam panels and distinctive custom decorative trim that create dynamic and shadow effects; Theodore Brown & Partners, architect, and Heather & Little, sheet metal contractor. **b)** Austin City Hall interior, Austin, Texas; Antoine Predock Architect. **c)** New York City storefront; Liz Saltzman Architects, Niko Contracting. **d)** Minneapolis City Hall, Minnesota; Long and Kees, architect. **e)** Arizona State College of Nursing, Phoenix, Arizona; SmithGroup, architect, and Kovach, Inc, installer. **f)** Copper repoussé. **g)** Hoboken Ferry Terminal, New Jersey; Kenneth M. Murchison, architect.

## COPPER ALLOY FAMILIES

### Coppers

Copper's architectural role now spans the functional role of protecting the building envelope with superior roofing, wall cladding and flashing systems, while providing decorative accents both inside and outside the building. All of the coppers listed in **Table 1** are suitable for these uses.

Architectural copper in sheet or strip form is cold-rolled. It should be specified to comply with ASTM B370, *Standard Specification for Copper Sheet and Strip for Building Construction*, which calls out metal that is 99.9% pure and prescribes specific thickness, flatness and mechanical property requirements. ASTM B370 defines six tempers. "Temper" is a semi-quantitative term that describes a metal's degree of hardening, most often by the cold work of rolling or drawing. Tempers listed under ASTM B370 (**Table 2**) include O60 (soft, *i.e.*, annealed), H00 (cold-rolled, 1/8-hard), H01 (cold-rolled, high yield, 1/4-hard), H02 (1/2-hard), H03 (3/4-hard) and H04 (hard). Other temper designations and their names are found in **Table 3**. Tensile properties of selected copper alloys compared with low-carbon steel, stainless steel and aluminum are shown in **Table 4**.

As hardness and strength increase, malleability decreases, thus the temper selected for a particular application will depend on an appropriate combination of these properties. Soft temper is normally reserved for ornamental work

**Figure II-2.** Extremely malleable, soft temper copper is the ideal medium for this finial (**a**) and hand hammered repousse fireplace mantle with spiral columns (**b**).



where malleability is initially more important than strength. Cold-rolled, 1/8-hard temper (H00) is by far the most commonly specified type, since it offers a useful compromise between these properties. Physical and mechanical properties are listed in **Table 1**.

ASTM B370 cites definitions and units traditionally used for sheet copper. Strip refers to material that is 24 in (61 cm) or narrower in width, while sheet refers to wider dimensions. And, because of the longstanding use of copper roofing, it's thickness is commonly represented in the traditional unit of weight in ounces per square foot. Typical dimensions of copper sheet and strip are listed in **Table 5**, and the relationship between weight and both Brown and Sharpe and U.S. Standard Gauges is given in **Table 6**. Architectural applications normally call for thicknesses ranging from 16 to 48 ounces per square foot.

Cold-rolled copper is also sold in tin-zinc alloy coated and lead coated forms. The coatings, applied by dipping in molten metal or electroplating, provide a matte gray to silver color. Upon exposure, these coatings weather to an equilibrium color tone corresponding to the metallic coating.

Tin-Zinc alloy coated copper is produced in both 16 and 20 oz thickness. Both 36-in x 120-in sheets and coils are available.

Lead-coated products may be prohibited in some jurisdictions; check with local authorities.



**Figure II-3.** The pleasing, naturally weathered, soft gray color on this roof and dormer is provided by lead-free, tin-zinc coated copper from Revere Copper Products.

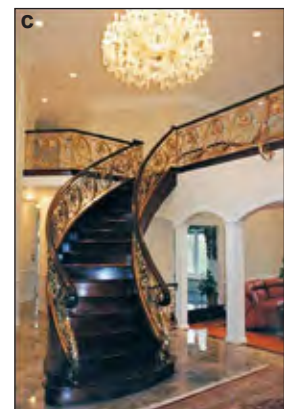
### Brasses

The brasses are very popular and are available in most product forms. Plate, sheet and strip are commonly used as interior wall and column cladding; tubular and rod forms lend themselves well to furniture and railings; while bronze wire can be employed effectively in screens and grillwork. Forging Brass (C37700), while traditionally thought of primarily as an industrial alloy, opens interesting possibilities when used for decorative forged hardware.

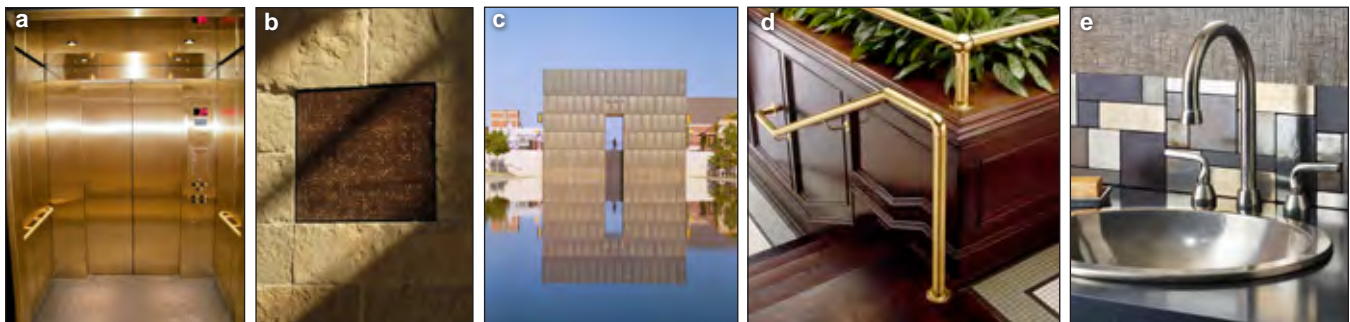
Brasses are used both indoors and outdoors, frequently for entrances and as trim. These alloys exhibit good welding characteristics, **Table 10**. Corrosion resistance is exceptionally high, but, unless periodically repolished, uncoated brasses will eventually weather to protective brown patinas. In hostile chemical environments, such as where salt spray is present, brass alloys with over 15% zinc should be avoided unless an inhibitor, like tin, is included in the composition.

### Bronzes

Bronzes are commonly named by their principal alloying addition, which imparts specific useful properties. Phosphor bronzes have a yellowish red color and is typically used for fasteners, welding rod and for heavy duty bridge plates. Silicon bronzes have a slightly pink to reddish hue in the natural state that prevents exact color matching with other members of the bronze family. However, silicon bronzes take chemical finishes well, making them desirable choices when color matching is important. Silicon bronzes demonstrate excellent corrosion resistance. Molten silicon bronzes exhibit the highest fluidity among copper metals and are therefore



**Figure II-4.** **a)** This cast and fabricated bronze balcony railing for an Indiana residence features no visible welds or fasteners. The component pieces were press-fit together using roll pins. Water-jet cutting speeded fabrication of many design elements. The finish is a satin grain (180-220 grit) with a clear lacquer. **b)** Cast bronze door hardware at Salt Lake City Hall, Utah. **c)** Custom, hand-forged, bronze handrail.



**Figure II-5.** **a)** Satin finished brass elevator interior exudes style. **b)** Decorative copper screen conceals air duct at Austin City Hall, Austin, Texas, Antoine Predock Architect. **c)** The Gates of Time, clad with naval brass (C46400), are one of the most striking features of the Oklahoma City National Memorial, Oklahoma City, Oklahoma; Butzer Design Partnership and Sasaki Associates, Architects. **d)** Durable and highly formable, brass is ideal for rails and fittings. **e)** Elegant nickel silver (white bronze) sink.

widely used for statuary and intricate castings. The alloy is quite attractive when used in its natural state and is equally attractive when darkened and oiled.

### Copper Nickels

These versatile alloys (sometimes referred to as cupronickels) are slightly pink in color and were primarily developed for industrial and marine uses. Their high tarnish resistance and durability makes them equally useful in coinage (the U.S. nickel, among others). Their antimicrobial properties — which they share with many other copper alloys, as described on page 9 — now promise interesting new architectural applications. The copper nickels are moderately strong yet favorably malleable and can be worked to complex shapes with ease. Weldability is excellent.



**Figure II-6. a)** Nickel silver door handles and **b)** antimicrobial copper nickel handrails are tarnish-resistant.

### Nickel Silvers

These copper-nickel-zinc alloys share many of the physical and mechanical properties of brasses but have a warm, silvery white color (even though they contain no silver). Traditional names for these alloys include “White Bronze” and “German Silver.” They are available as wrought and cast products and are often used in combination with other copper metals in complementary juxtaposition. They have excellent corrosion resistance, are durable, and weather well, although they are generally used indoors.



**Figure II-7.** Fabricated by DeAngelis Ironwork Inc., South Easton, Massachusetts, from all nickel silver components from Julius Blum. The top rail is a molded cap. The interlocking oval segments were formed hot and brazed to one another. Fasteners were concealed by brazing in matching nickel silver plugs. All components received a satin brush finish.



**Figure II-8.** Nickel silver accents provide a soft silver hue to the Waldorf Astoria Hotel, New York, New York.

### INTERNATIONAL DESIGNATIONS

Copper alloys are also classified by the International Standards Organization (ISO), European standards, (EN), and various national systems, including the Japanese Industrial Standards (JIS), British Standards (BS) and the German DIN. Cross-reference publications are available from several sources, including associations and technical societies such as CDA and ASM International.<sup>3</sup> Aside from coppers and simple alloys, color matches between these alloys and UNS compositions are possible but must be found by trial and error. Differences among alloys can also affect weathering behavior.



---

## III. PHYSICAL PROPERTIES AND APPEARANCE

---

### ANTIMICROBIAL PROPERTY OF COPPER

Perhaps, the most exciting property shared by nearly half of all copper alloys is their inherent antimicrobial capability.<sup>4</sup> Tests to validate this important attribute were conducted by an independent laboratory certified by the U.S. Environmental Protection Agency using EPA-prescribed protocols. The tests conclusively demonstrate that disease-causing bacteria, including methicillin-resistant *Staphylococcus aureus* (MRSA), *E. coli* O157:H7, *Enterobacter aerogenes* and other species are killed on copper alloy surfaces.<sup>1</sup>

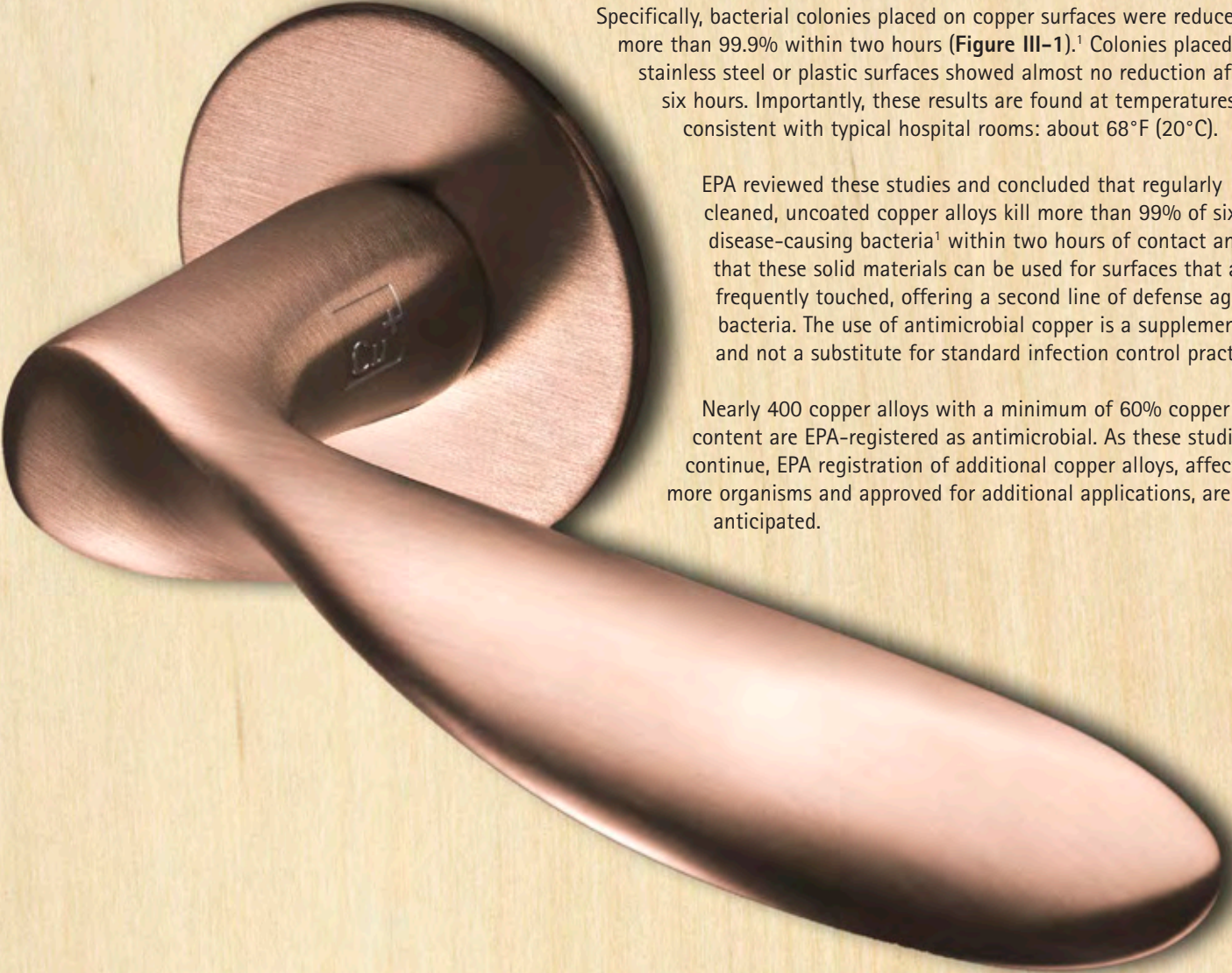
Widely publicized statistics from the Centers for Disease Control and Prevention (CDC) estimate infections acquired in U.S. hospitals affect two million individuals every year, resulting in nearly 100,000 deaths and costing up to \$45 billion annually. Impressive results from clinical trials in Birmingham, England; Calama, Chile; and three U.S. hospitals demonstrate that the use of copper alloys on frequently touched surfaces in hospitals have the potential to reduce microbial contamination significantly, compared with non-copper surfaces.

#### Effectiveness

Specifically, bacterial colonies placed on copper surfaces were reduced by more than 99.9% within two hours (**Figure III-1**).<sup>1</sup> Colonies placed on stainless steel or plastic surfaces showed almost no reduction after six hours. Importantly, these results are found at temperatures consistent with typical hospital rooms: about 68°F (20°C).

EPA reviewed these studies and concluded that regularly cleaned, uncoated copper alloys kill more than 99% of six disease-causing bacteria<sup>1</sup> within two hours of contact and that these solid materials can be used for surfaces that are frequently touched, offering a second line of defense against bacteria. The use of antimicrobial copper is a supplement to and not a substitute for standard infection control practices.

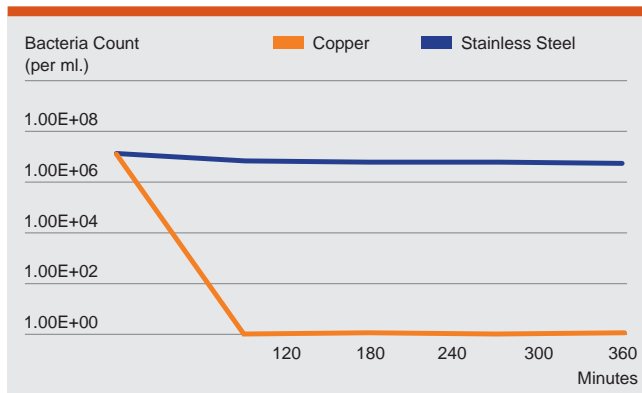
Nearly 400 copper alloys with a minimum of 60% copper content are EPA-registered as antimicrobial. As these studies continue, EPA registration of additional copper alloys, affecting more organisms and approved for additional applications, are anticipated.



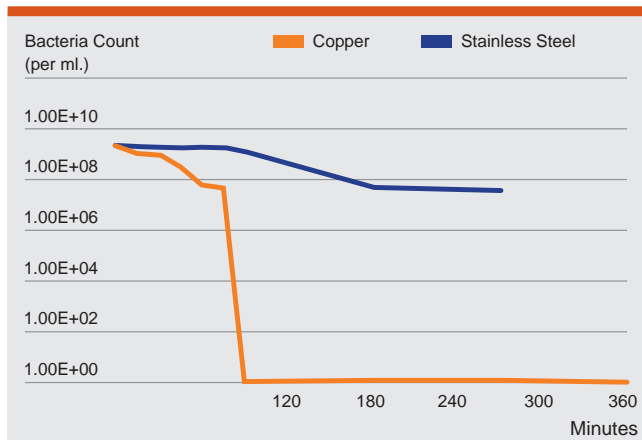
---

*Bacterial contamination can be mitigated quickly with antimicrobial copper alloy door hardware.*

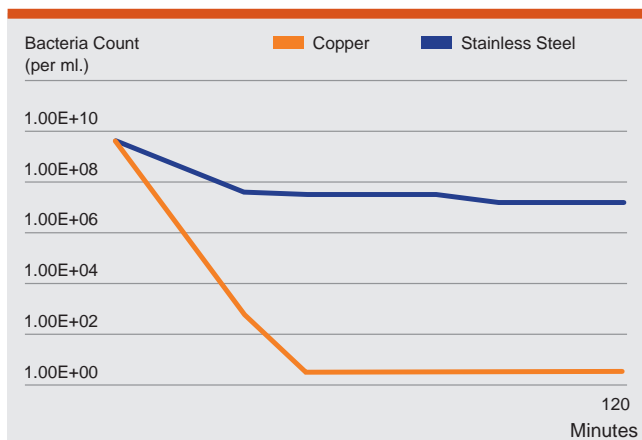
**Viability of MRSA  
on Copper and Stainless Steel at 68°F (20°C)\***



**Viability of *E. Coli* O157:H7  
on Copper and Stainless Steel Surfaces\***



**Viability of *Enterobacter Aerogenes*  
on Copper and Stainless Steel Surfaces\***



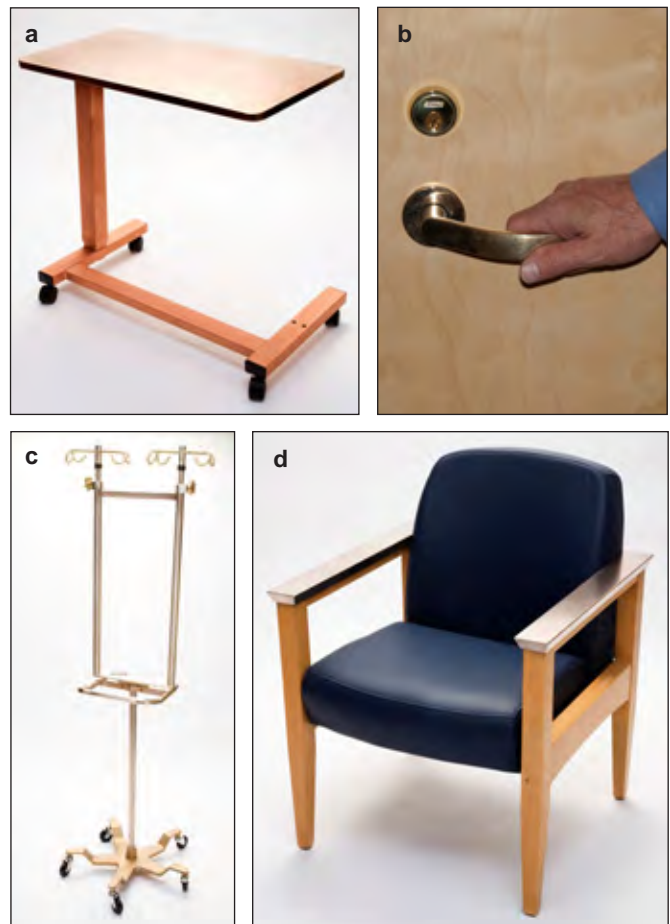
\* Stainless steel was used as a control material (as required by the U.S. EPA) in all registration efficacy testing of copper and copper alloys.

**Figure III-1.** Three graphs show the dramatic reduction of pathogens within minutes of contact with a copper surface. Similar results are achieved by nearly 400 EPA-registered copper alloys.<sup>1</sup>

**Clinical Trials**

Clinical trials at major hospitals in the United States, Chile, Germany, United Kingdom and Japan have evaluated critical touch surfaces in typical patient care settings where prototypes of hospital equipment made from antimicrobial copper alloys were installed.

The U.S. clinical trials included IV poles, bedrails, overbed tables, room furniture, medical equipment and other items. *Copperized* equipment installed in the hospital rooms were swabbed for microbial contamination and were compared with non-copper equivalents in control rooms. The impact of copper surfaces on surface contamination and, eventually, infection rates was investigated in these trials. Recently compiled results show microbial contamination reduced by more than 83% average and infection rates decreased by 58% in the intensive care units studied.<sup>5</sup>



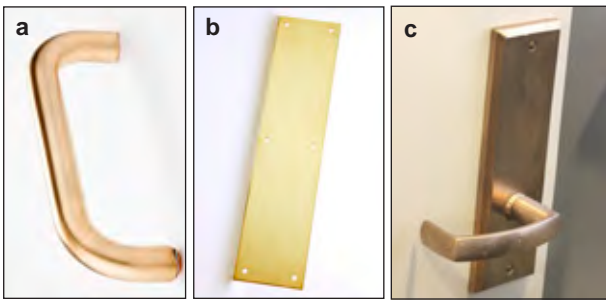
**Figure III-2.** Antimicrobial copper products for use in U.S. clinical trials: **a)** copper-clad overbed table, **b)** copper nickel door hardware, **c)** copper nickel IV pole, **d)** copper-clad arm chair.

## Considerations

To maintain the intrinsic antimicrobial property of copper, products must not be painted, lacquered, varnished, waxed or coated in any way. As with liquid and gaseous disinfectants, antimicrobial copper alloys have been shown to reduce microbial contamination but do not necessarily prevent cross-contamination. Tarnishing does not impede the antimicrobial performance of copper alloys.

Manufacturers, fabricators and suppliers who have EPA registration may, upon entering into agreement with CDA, use Antimicrobial Copper™ and the Cu+ marks to indicate their products are made from EPA-registered antimicrobial alloys.

No other architectural metals, whether coated or not, exhibit the copper metals' antimicrobial efficacy. The copper alloys' antimicrobial property can be especially valuable when used for touch surfaces such as push plates, door and window hardware, railings, countertops and a multitude of common applications in public venues. However, the use of a copper alloy surface is a supplement to and not a substitute for standard infection control practices; users must continue to follow all current infection control practices, including practices related to cleaning and disinfection of environmental surfaces.



**Figure III-3.** a), b) and c) uncoated EPA-registered antimicrobial copper alloy door hardware have been shown to reduce microbial contamination.

Copper C11000*	Admiralty Metal C44300*	Aluminum Bronze C63000*	Copper Nickel C70600*
Commercial Bronze C22000*	Phosphor Bronze C51000*	Silicon Aluminum Bronze C64200*	Copper Nickel C71500*
Red Brass C23000*	Phosphor Bronze C52100*	Silicon Bronze C65100*	Nickel Silver C75200*
Brass C24000*	Aluminum Bronze C61400*	Silicon Bronze C65500*	Nickel Silver (Coin) C76400
Cartridge Brass C26000*	Aluminum Bronze C62400*	Silicon Manganese Aluminum Brass C67400	Tin Bronze C90700
Yellow Brass C27000*	Aluminum Bronze C62500*	Manganese Bronze C67500	Aluminum Bronze C95400*

**Figure III-4.** The distinctive colors of copper alloys make an attractive palette for architectural and consumer applications, as well as objects of art. Alloys marked with an asterisk (\*) are EPA-registered as antimicrobial copper alloys.

## GENERAL PROPERTIES AND COLOR

Architectural coppers are supplied as essentially elemental metal whose purity will be greater than 99.90%. Physical properties vary only slightly with the degree of purity; the largest differences are in electrical and thermal conductivities. Corrosion and weathering properties of a given alloy are likewise similar, except in special circumstances not ordinarily encountered in architectural applications. Mechanical properties, chiefly strength and ductility, are affected by the degree of cold work (temper) imparted during manufacture, as described in **Table 4**.

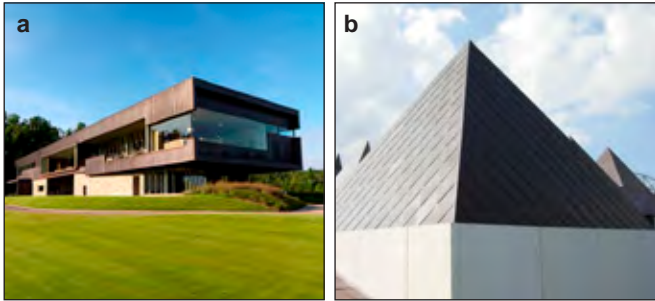
Alloy composition can also impart profound effects on both mechanical and physical properties such as color, corrosion resistance, machinability and wear resistance.

For example, zinc, the most common alloying element, is responsible for the yellow tone of brasses, the effect being a more pronounced lightening as zinc content increases. Tin has a similar effect in bronzes, while silicon and nickel impart a pinkish hue when present in low concentration. High nickel content, combined with zinc, imparts the silvery color to nickel silvers. Used alone, nickel yields the subdued gray seen in the U.S. nickel coin.

This is the beauty of the metals, but in print it is impossible to provide more than a representation of the basic colors of any individual alloy. **Figure III-4** attempts to show the beginning natural color of several distinctive alloys. It provides a reference as you create a color palette for your architectural design. See **Color Matching**, page 12.

One of the significant architectural attributes of copper alloys is that they are *living metals*. Just as a picture of any living person changes from exposure to exposure, so does the appearance of any metal. The amount of light, the type of light and its orientation have pronounced effects. Likewise, the finishes of metal surfaces, the colors reflected from surrounding surfaces, and the duration and type of exposure to the environment provide nuances of visual perception that are constantly varied and constantly in movement.

Copper metals weather over time based on the degree and type of exposure. In moist climates, copper typically begins as a reddish salmon pink and then progress through deepening browns to the greenish blue of a mature patina. In arid climates, the coloring tends to move through various shades of brown to a walnut hue (**Figures III-7** and **8**, page 13). The patination process is actually a benign form of corrosion; relatively



**Figure III-5. a)** Blessings Golf Clubhouse at the Fred and Mary Smith Razorback Golf Facility, Johnson, Arkansas; Marlon Blackwell Architect. **b)** Art Museum of South Texas, Corpus Christi, Texas; Legoretta + Legoretta Architects.

rapid at first, but then slowing to an imperceptible rate after several years' exposure, depending on the ambient climate and environment. Vertical surfaces weather more slowly than horizontal. The end result is the nearly complete protection of the underlying metal from further attack. The color changes in indoor environments are much slower and more subtle.

The composition (and therefore color) of the patina is determined by the type and nature of atmospheric constituents present (principally moisture, sulfides, sulfates, carbon dioxide, chlorides). In brasses and bronzes, the patinas' make-up and appearance is additionally influenced by the alloy composition.

Compositions, selected properties and specification standards for common product forms for architectural copper metals are listed in **Table 6**. A comprehensive list of these and other properties for all UNS copper metals is available on line at [www.copper.org/resources/properties/homepage.html](http://www.copper.org/resources/properties/homepage.html).

### Color Matching

Different product forms are often used together; e.g., extrusions with tube in handrails and balusters, castings or forgings and rod or bar in hardware (**Figure III-6**). Unfortunately, not all copper alloys are produced in every product form; therefore, if color uniformity is an issue, it is necessary to select different alloys with the same color. In the case of outdoor uses, it may also be necessary that the metals weather at approximately the same rate and to the same desired tone. **Table 7** compares sheet and plate alloys with those produced in other forms on the basis of surface colors after identical grinding and polishing. Consider also, that intentionally using alloys of different colors can produce striking effects.

### Corrosion Resistance

Copper is chemically classified as a "noble" metal, sharing that distinction with silver and gold. Noble metals resist oxidation and react less readily with other substances than do more chemically active metals. Copper does oxidize in air, and it does react with some atmospheric and waterborne

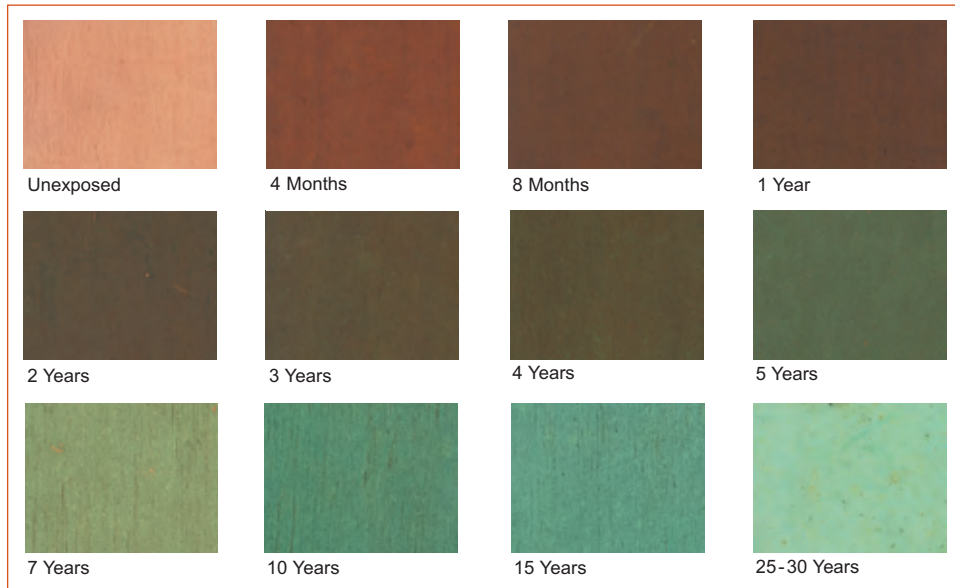
chemical species. However, the resulting general corrosion reactions are slow and are self-limiting in that they protect the underlying metal against long-term attack by forming the tenacious corrosion-product films we know as tarnishes and patinas. Copper metals exhibit a wide range of responses to industrial chemicals and atmospheres, and readers should consult the *Copper & Copper Alloy Corrosion Resistance Database* at [www.copper.org](http://www.copper.org) for information regarding specific alloys and environments.

Chemical nobility is a relative term, and one of any pair of metals or alloys can be correctly described as being more noble or less noble than the other. Armed with that knowledge, it is possible to select metals and alloys that can safely be placed in contact with each other based on their comparative nobility. This is depicted graphically in the Galvanic Series shown in **Figure III-9**. Metals that are adjacent to or near each other horizontally in the series are less likely to promote galvanic corrosion than those that are farther apart.



**Figure III-6.** Various copper alloys and alloy forms can be color-matched or color-contrasted to achieve a unified or complementary look. **a)** Ohio State Courthouse in Columbus, Ohio, assorted bronze and nickel silver extrusions by Mac Metals. **b, c)** Extruded architectural bronze (C38500) cast cap brazed to a cast ounce metal (C83600) volute and finished to a seamless appearance, R & B Wagner, Inc. **d)** Although this door and sidelight set are manufactured from three copper alloys of very different color tones, Wiemann Metalcraft used chemical weathering techniques for a perfect color match.

**Figure III-7.** Natural Weathering Color Chart (typical for most moist industrial climates, timespans may vary).



**Figure III-8.** The two figures on the left show typical weathering on vertical surfaces, while those on the right show how weathering differs on sloped surfaces. **a)** Sam Noble Museum, Norman, Oklahoma, semi-arid climate, 12 years after installation; Solomon+Bauer+Giambastiani Architects and Kaighn Associates Architects; **b)** Georgia Public Health Lab, Atlanta, Georgia, humid climate, 12 years after installation, Lord Aeck & Sargent, architect. **c)** Denver Public Library, Denver, Colorado, semi-arid climate, 17 years after installation, Michael Graves, architect; **d)** Gazebo, Decatur, Georgia, humid climate, 15 years after installation, Edwin Terrel Meek / Architect.

For example, copper and copper alloys can be used with comparative safety in direct contact with each other, and many with stainless steels. In most situations, it is important to avoid plain carbon steels, galvanized (zinc-coated) steels or aluminum, which are significantly farther to the left in the figure and less noble (more active).

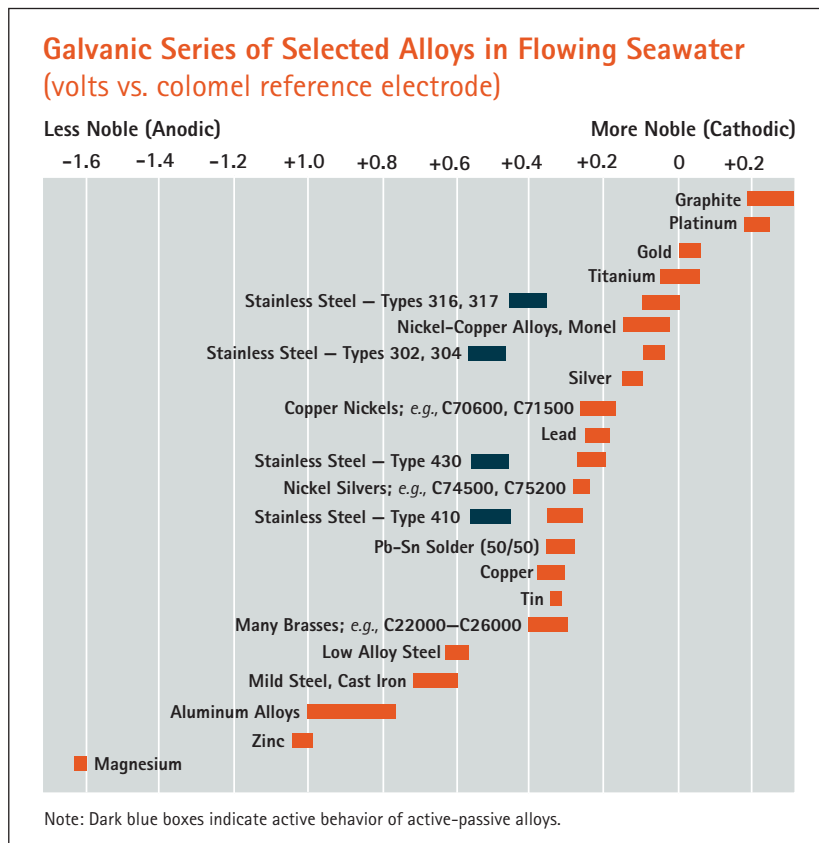
If dissimilar metals must be placed in close proximity, they should be electrically insulated from each other. For example, copper roofing can be insulated from steel purlins or galvanized nails used to attach wood purlins by interposing a layer of bitumen-infused felt or paper. Other insulating barriers include plastic washers, insulation tape, inorganic zinc coatings, trivalent chromates and other primers. Most avoid zinc chromate and red lead (minimum) due to their potentially toxic effects.

Joints made with dissimilar metal fasteners provide one of the common instances in which galvanic corrosion can arise. An example is shown in **Figure III-10** in which steel rivets corrode aggressively while adjacent copper sheet remains protected. The figure also illustrates the effect of relative

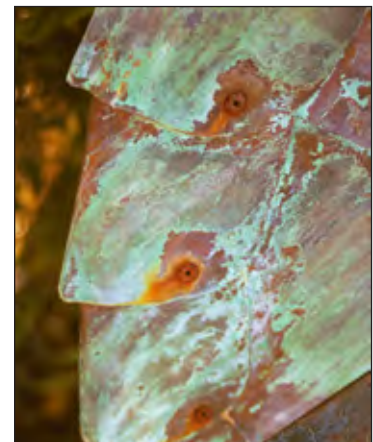
areas. In this case, the surface area of the less noble steel is significantly smaller than that of the more noble copper metal, thereby accelerating the attack. Conversely, were the metals reversed (*i.e.*, small copper rivets and large steel sheet), corrosion of the steel would proceed much more slowly, if at all.

Mechanical joints in copper-metal assemblies are preferably made with screws, bolts or rivets made from copper alloys appropriate to the level of strength required. Galvanic corrosion is rarely encountered among the copper alloys when used in close contact. In general, the copper base alloys have similar nobility and are galvanically compatible with each other, except in seawater in cases where the surface area of the more noble alloy is significantly greater than the less noble alloy.

Color matching is simplified, since companion fastener alloys are available (**Table 7**) for most copper metals. Strength and color-matching characteristics for these fastener alloys are shown in **Table 8**.



**Figure III-9.** Metals adjacent to or near each other horizontally in the series are less likely to promote galvanic corrosion than those that are farther apart.



**Figure III-10.** Steel rivets used to join sections of exposed copper sheet create an ideal opportunity for galvanic corrosion. In this case, less noble steel corrodes while more noble copper remains protected. Corrosion is accelerated by large differences in area size between the two metals.

## IV. FABRICATION METHODS



**Figure IV-1.** Ease of fabrication makes brass the ideal metal when forming graceful curves characteristic of both musical instruments and a myriad of architectural applications.

The copper metals' versatility in forming and fabrication offers an abundance of choices from which to create both decorative and functional elements. The metals are readily worked, both in sheet and other forms. They are equally well-suited to virtually all casting methods, and they can be joined by virtually any technique at the craftsman's disposal. The following paragraphs describe common forming and fabrication methods and their suitability to specific alloys. Illustrated examples hint at ways in which these methods can be applied to copper.

### FORMING

#### Bending

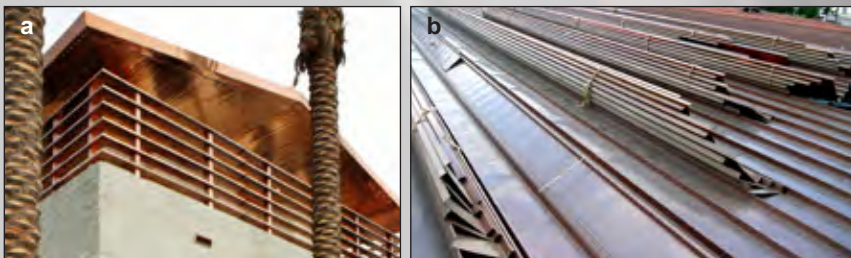
The simplest of forming methods, bending, is a mechanical process conducted at either ambient or elevated temperatures to create simple (*i.e.*, not compound) curves in sheet, strip, plate, rod, tube or extruded shapes. Accurate bends might require the use of rollers, guides, bending shoes or mandrels to avoid buckling or nonuniform deformation. Bending is applicable to many alloys, including coppers C11000, C12200 and C12500; brasses C22000, C23000, C26000, C28000, C38500 (hot), C46400; bronzes C65100 and C65500; copper nickels C70600 and C72500; and nickel silver C74500.



**Figure IV-2.** Copper alloys installed on this staircase at the European American Bank, New York, New York are examples of simple bending. The handrail is a solid extrusion of architectural bronze, C38500; stringer cladding is Muntz metal, C28000.

#### Brake Forming

Brake forming creates simple curves or angles in straight lengths of sheet, strip and plate. Section length is limited to the size of the available brake. Longer elements are frequently processed by roll forming **Figure IV-3**. Brake forming can be applied to many alloys including: coppers C11000, C12200 and C12500; brasses C22000, C23000, C26000, C28000, C38500 (hot), C46400; bronzes C65100 and C65500; copper nickels C70600 and C72500; and nickel silvers C74500 and C79600.



**Figure IV-3.** a) Rails and posts for this balcony were brake-formed in the factory and installed on site in Las Vegas, Nevada. b) Long-length repetitive profiles, such as these site-formed roofing panels for installation on Austin City Hall, Austin, Texas, are commonly roll formed.

*Furnace-heated copper immediately after extrusion*

## Roll Forming

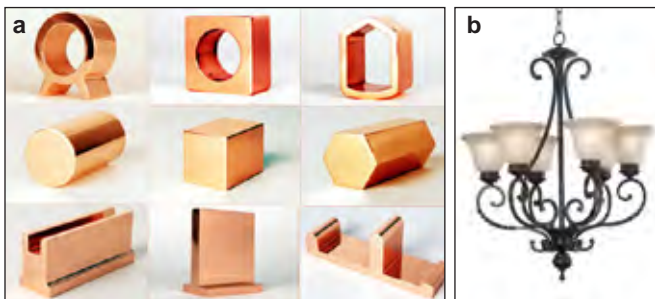
Shapes and/or angles are produced in sheet and strip by passing the material between one or more stands of contoured rolls. Corners are generally not as sharp as those resulting from brake forming. Simple roll-formed products include corrugated panels, standing seam roof panels and gutters. The process is also used to produce complex custom shapes for decorative architectural elements, such as window and door frames, especially when a number of similar products need to be fabricated.



**Figure IV-4.** The long, diagonal panels gracing the saddle-roof of the San Angelo Museum, San Angelo, Texas, provide a distinctive perspective of the structure from all angles; HHPA, architect.

## Extrusion

The extrusion process is likened to squeezing toothpaste from a tube. Heated metal is forced under pressure through a die opening shaped to the desired cross-section of the end product. The process is commonly used to make railings and any number of tubular or complex shapes. All copper alloys can be extruded.



**Figure IV-5. a)** Complex elements of fit, form and function are easily handled by the extrusion process. **b)** forged bronze lamp by Kenroy Home.

## Casting

Copper metals are cast to intricate shapes by all conventional foundry methods, including pressure die-casting. Castable alloys are identified by the C80000 and C90000 series of UNS designations. Popular cast architectural alloys include silicon bronze C87300, ounce metal C83600 and the nickel silver C97300. Finest details can be cast in silicon bronze, which exhibits especially high fluidity when molten. The alloy is commonly used for statuary.



**Figure IV-6. a)** These art deco sliding doors are cast from C83700 silicon bronze and are modeled after antique elevator doors found at the Essex House Hotel in New York City. The visible surface is sand-cast bronze. Highlights were polished and brushed before application of clear lacquer coat. **b)** This beautiful bronze railing in San Francisco, California demonstrates long-term weathering tones characteristic to many areas.

## Forging

Performed hot or cold, principally for industrial products, forging is also used to manufacture high-quality architectural elements including decorative switch plates and door hardware. Products are normally stocked items since the cost of forging dies precludes quantities fewer than several thousand pieces. Many copper alloys can be forged, although Forging Brass, C37700, is a common choice.



**Figure IV-7. a)** Solid forged brass door pulls from Andersen Corporation in six distinctive styles and finishes. **b)** A forged brass entry lockset.



## Stamping

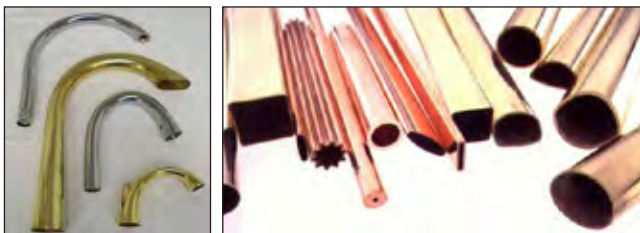
Stamping defines a variety of processes including bending, shaping, cutting, indenting, embossing, coining and forming using shaped dies and a power press or hammer. Applicable to sheet, strip and plate products made from many copper alloys, particularly coppers C11000, C12200 and C12500; brasses C23000, C26000, C28000; bronzes C65100 and C65500; and nickel silvers such as C74500 or C75200.



**Figure IV-8.** Decorative panels on the Frank Lloyd Wright-designed Price Tower in the prairie town of Bartlesville, Oklahoma, demonstrate one of the effects possible from stamping. The vertical copper panels would not have weathered blue-green in this climate, but Wright loved the color and had the panels chemically patinated prior to installation.

## Hydroforming

In this interesting process, malleable sheet metal is placed over a male punch or die-half and hydraulically pressed, forming the metal to the desired shape. If the metal to be formed is thin and soft enough, inexpensive dies can be made from laid-up, reinforced plastic composites such as fiber glass, thus making the process economically viable for a limited number of products. The process is similar to vacuum forming, in which metal is drawn against a female die-half. Variations of the process are used for deep drawing special shapes and tube forming.



**Figure IV-9.** Complex shapes can be created by hydroforming. It is used to form component pieces for the automotive, plumbing, musical instrument and many other industries. Its advantages include: reduced weight, smaller production runs, lower component costs and tighter tolerances.

## Spinning

A process to form circularly symmetric shells by working sheet stock over a mandrel as the mandrel spins. Commonly spun architectural objects include hollow brass door knobs, small seamless domes and light fixture components.



**Figure IV-10.** Copper globes, fabricated from spun and brake-formed components, adorn four towers at the corners of the Ellis Island Immigration Museum in New York Harbor, New York, New York.

## Laminating

Any copper-metal sheet and strip alloy can be laminated to substrates to form composite panels. Such panels typically do not require cross-crimping or any further reinforcement to avoid waviness. Interior and exterior composite wall panels are relatively light in weight and can exhibit exceptional flatness.



**Figure IV-11.** Copper laminate panels, from ALPOLIC, wrapping the Ceridian Corporation Headquarters in Minneapolis, Minnesota, will naturally weather in harmony with its surroundings.

## Explosive Forming

Chemical explosives force sheet or plate against a single die half. Very large architectural elements are formed in this way without having to resort to large equipment. Explosive forming can be used with many coppers alloys. Although used infrequently, this process produces intriguing results.



**Figure IV-12.** Explosive forming is suitable for many copper alloys. It can create small artistic detail, such as this bas-relief panel section from Evelyn Rosenberg's Metamorphosis, or to large bulbous elements such as building corners and other rounded shapes.

## JOINING

Three common means to join copper and copper alloy components are seaming, fastening and metallurgical bonding. Each serves a specific structural function and should be used appropriately. Aside from their functional purpose, each has a distinctive appearance and can be used decoratively.

### Seamed Joints

Standing, batten or flat seams common for roofing are suitable for interior use creating unique and dramatic shadow lines. These systems are attached to the underlying substrate with concealed fasteners, providing a smooth look. Many different shapes and patterns can be created using these types of seaming techniques. For example, lapped seams and connections with exposed fasteners can create a unique wall treatment.



**Figure IV-13.** Seams between individual sheet copper panels create a decorative pattern in the vestibule of Central Connecticut State University's Student Center in New Britain, Connecticut.

### Mechanical Fasteners

Screws, bolts and rivets are all commonly used to connect pieces, either to each other or to an underlying structure. Galvanically compatible fasteners should be used in order to avoid corrosion as mentioned in **Chapter III**, page 14. Color matching is simplified by the availability of fasteners in alloys compatible with most copper metals. Alloys commonly used for fasteners have strength and color-matching characteristics shown in **Tables 7** and **8**. See discussion in the chapter on **Physical Properties and Appearance**, page 9.

For interior applications, exposed fasteners can be arrayed in patterns to play a key role in the aesthetic design. Decorative "bolts" can also be used to reinforce a pattern or create a dimpled effect. Blind mechanical fastening techniques can be

used in some cases when formed panels are installed in a predetermined pattern with a small space between the panels forming a linear sightline.



**Figure IV-14.** There is a copper, brass or bronze fastener for nearly every mechanical joint requirement. Many stainless steels and nickel alloy fasteners are also compatible, as are lead anchors, which are frequently used to secure fasteners in masonry.

### Metallurgical Joining Processes

Metallurgical or fusion joining processes include (in order of increasing process temperature) soldering, brazing and welding. Only during welding is the base metal actually molten. The three processes are described in **Table 9**.<sup>6</sup>

For a smooth finish, copper can be welded, and, if desired, the welds can be ground down to appear flush, providing a seamless look. This technique is frequently used on edges of heavier gauge copper counters.

In some cases, metallurgical process methods can be used to create designs. When thinking about techniques using high heat input, consideration must be given to the possibility of thermal discoloration of the metal. In some installations, heat tinting is used to create additional effects.

With a few caveats, copper metals lend themselves well to metallurgical joining: all can be soldered and brazed, and many can be fusion- or resistance-welded. Exceptions include C11000 copper, which can present difficulties in welding, owing to its oxygen content. When welding is planned, users should specify deoxidized grades such as C12200 and C12500 instead. Lead-containing alloys should, in general, be soldered or brazed, since they are difficult to weld. **Table 10** lists the suitability of the various processes to the copper metals most often used in architecture.

Give careful consideration to color matching when specifying exposed metallurgical joints. Solders and some brazing alloys are silver-colored and match only the nickel-silver alloys. In some situations, the amount of exposed solder can be abrasively reduced to show only a minimal seam. In most cases,

---

this is not an issue. In others, such as most roofing and gutter work, the soldering can be done within the gutter where it is rarely observed.

Among the true welding filler metals used in architectural applications are deoxidized copper (AWS A5.7 ERCu), which matches the architectural coppers C11000, C12200 and C12500; silicon bronze (AWS A5.7 ERCuSi-A), a medium strength bronze that is slightly redder than architectural bronze, C38500; and aluminum bronze (AWS A5.7 ERCuAl-A2), which is stronger than silicon bronze but slightly lighter in color. Silicon bronzes (C65100 and C65500 as wrought products and C87300 as castings) are easily welded using C65600 (AWS A5.7 ERCuSi-A), a filler metal with an excellent color match.



**Figure IV-15.** Seamed and mechanical joints were employed to fabricate this chimney cap.



**Figure IV-16.** JT Cooper Studios creatively used brazing alloy to create texture and decorative seams for this door.

## V. DESIGN AND INSTALLATION GUIDELINES

The installation and use of copper architectural products is straightforward, but a few practical guidelines must be observed if designs are to be realized properly at reasonable cost. Guidelines for cast products are not included here; their properties and uses are described in the CDA publication, *Copper Casting Alloys* (A7014) available at [www.copper.org/publications](http://www.copper.org/publications).

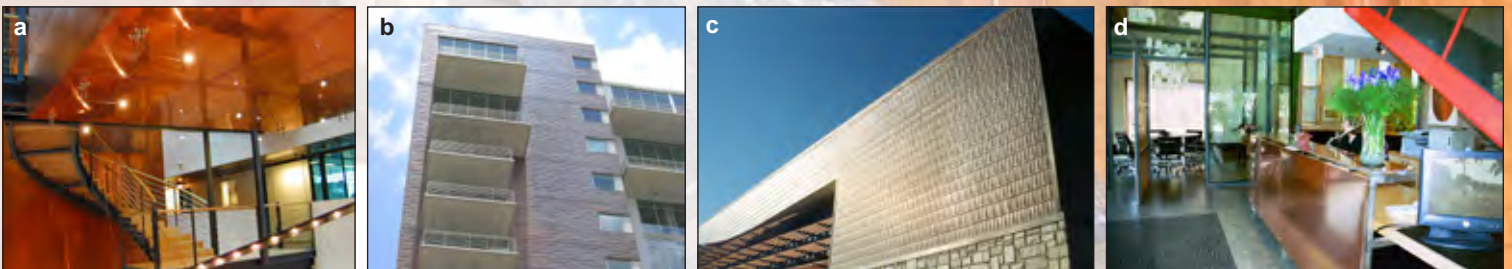
### SHEET, STRIP AND PLATE

These products are produced with good flatness and few defects, but preserving those qualities in service requires careful design, construction and maintenance. There is an inherent tendency for thin sheets to ripple or display "oil-canning." It is an inherent feature of light gauge sheet metal and should be considered by the designer. Sun exposure, panel width, seam height, sheet thickness, fluting, swaging and tension-leveling can contribute to or mitigate the effect. Specular (highly polished) finishes amplify the appearance by magnifying and sometimes highlighting distortions.

Textured finishes, sculpted contours and patinated or chemically treated surfaces may reduce distortion and/or help make oil-canning less visible. For some applications, distortion can be avoided by using either composites or thicker sheet material. Plywood-backed laminates provide similar protection but are more sensitive to temperature and humidity.

The following guidelines apply universally, but are particularly helpful for installations in well-lighted locations:

- For nonlaminated sheet or plate, larger areas require thicker metal to avoid distortion.
- Broad areas of flat sheet thinner than 0.10 in (2.5 mm) should be avoided, unless waviness is desired.
- The need for cross-crimping has been reduced by the availability of laminates. However, it does reduce the tendency for buckling and can lower the minimum useable thickness for large panels to between 0.064 in and 0.10 in (1.6 mm and 2.5 mm). Introducing a regular pattern, such as by embossing, lowers the permissible sheet thickness to as little as 0.032 in (0.8 mm), but, depending on exposure, the patterned surface may still be vulnerable to denting.



**Figure V-1** **a)** Flat, mirror-finish copper clads the interior of the Finnish Embassy; Washington, D.C. **b)** The oil-canning typical in light gauge sheet metal adds texture to the face of the City Lofts building in Austin, Texas; Pageg Southerland Page, Architect. **c)** Striking wall cladding of stamped copper shingles distinguish this Atlanta, Georgia lab building; Lord Aeck Sargent, Architect. **d)** A polished copper panel and countertop highlight this reception area.

*Standing seam panels adapt to both roofing and wall cladding.*

- Areas maintained by hand cleaning, polishing, lacquering, waxing or oiling may be at risk to denting if the metal is not sufficiently thick or uniformly supported to withstand the applied forces. Some surfaces, both flat and curvilinear can be protected by backing them with a rigidizing agent such as foam. Keep in mind that some foam or adhesive products may be corrosive to copper alloys; verify compatibility with their manufacturer.
- Metal between 0.05–0.12 in (1.25–3.00 mm) thick is typical for column covers, door and window frames, mullions and similar elements. A common thickness is 0.064 in (1.6 mm).
- Monumental work (*viz.* impressively large, sturdy, and enduring) commonly uses thicker material; 0.080 in (2.00 mm) is common. Thicker material is less vulnerable to damage and may prove more cost-effective on such projects. The Statue of Liberty provides an excellent example: It's copper skin was originally 3/32 in (0.094 in, 2.4 mm) thick. It has lost only five percent thickness (0.005 in, 0.013 mm) since installation more than a century ago.

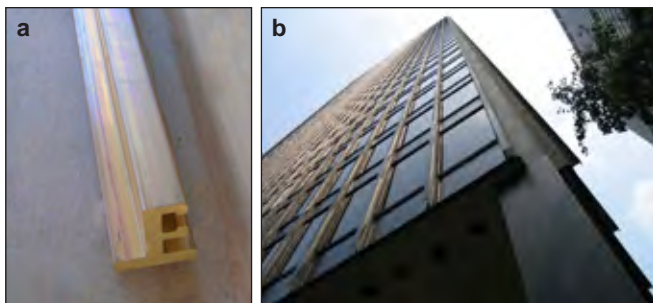


**Figure V-2.** Statue of Liberty, New York Harbor.

For detailed information regarding roofing, gutter, downspout and flashing gauges, sizes and joining techniques, see CDA's *Copper in Architecture Handbook*, Publication No. 4050, available at [www.copper.org/publications](http://www.copper.org/publications).

## EXTRUSIONS

Extrusions are available in a large selection of standard shapes and sizes. Custom profiles are possible at little additional cost. Consult extrusion mills when selecting a specific alloy for an extruded product. There are several North American suppliers, some of which specialize in architectural products.<sup>7</sup>



**Figure V-3.** a) Custom extrusion designed to structurally attach large copper wall panels. b) Architectural bronze extrusions on the world-famous Seagram Building, New York, New York.

Standard shapes include U-shaped channels and Z-, L-, H- (or h-), E-, F- and T-sections. Tubes and rods are extruded products that are drawn or rolled to final size. Products are normally shipped in lengths from 12 to 16 feet (3.7 to 4.9 m) long, but extrusions up to 32 ft (9.75 m) are available. End-use products utilize either the full extruded length or cut-to-order sections.

A successful extrusion is one in which metal fills all portions of the profile equally, enabling product to exit the die in straight lengths. Metal flow is governed by thicknesses of individual web sections. Minimum thickness of individual webs is limited by overall size of the cross section, normally described as the diameter of a circumscribing circle. **Table 11** lists minimum gauges for several cross-section diameters. Preferred minimum web thickness for most architectural extrusions is 0.080 in (2.03 mm). Thinner sections can be produced, but doing so usually entails cost premiums.

Channel sections are the most common extrusions. A general rule of thumb is that the width of the channel should not exceed its depth. However, very deep channels can be assembled as sections, or produced in one piece by brake forming. Sections with uniform web thicknesses extrude best; otherwise, the ratio of thick-to-thin sections should not exceed 2:1. A profile containing a thin, wide flange should be designed to include a bend or enlargement at the end of the flange to ensure uniform metal flow during extrusion. Design criteria are illustrated in **Figure V-5**. When one-piece extrusions are impractical, two or more can be joined by a variety of techniques, as illustrated in **Figure V-6**.

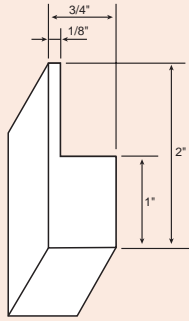
## TUBE

Standard products are round, square or rectangular (**Figure V-7**). Railings and balusters are among the many architectural uses for tube products. Hexagonal and octagonal shapes are available by special order. Copper and all of its alloys can be supplied as tube, the most common being coppers C11000, C12200 and C12500; brasses C22000, C23000, C26000 and C46400; copper nickel C71000; and nickel silver C74500.

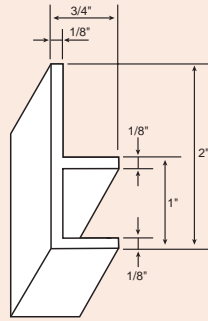


**Figure V-4.** Brass tubular products come in many forms, displaying a variety of classic or modern styles and performing durably for years.

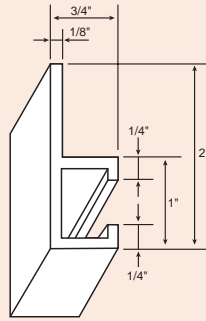
**Figure V-5. Basic Design Criteria for Bronze Extrusions**



1

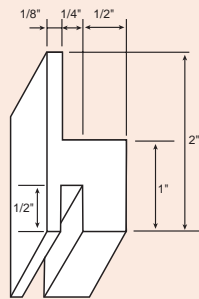


2

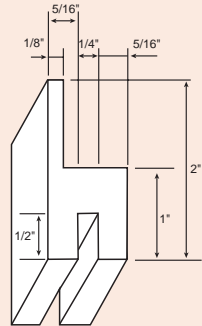


3

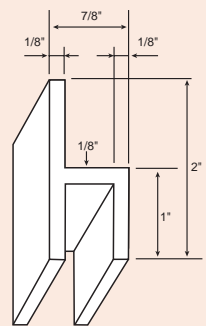
- 1 Impractical. Because material flows through the path of least resistance, the 1/8-inch leg will not fill properly.
- 2 Practical
- 3 Practical



1

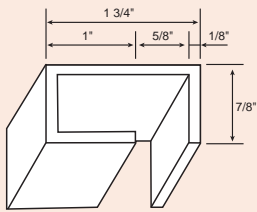


2

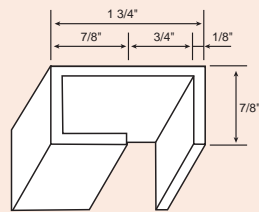


3

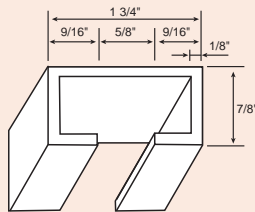
- 1 Impractical. The off-center position of the tongue (lower left) in the die will create unequal pressures and cause the tongue to bend resulting in a distorted groove.
- 2 Practical
- 3 Practical



1

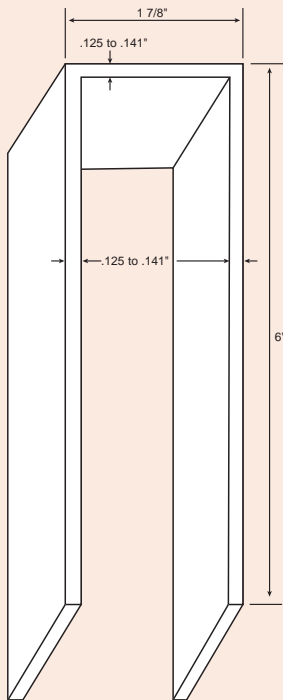


2

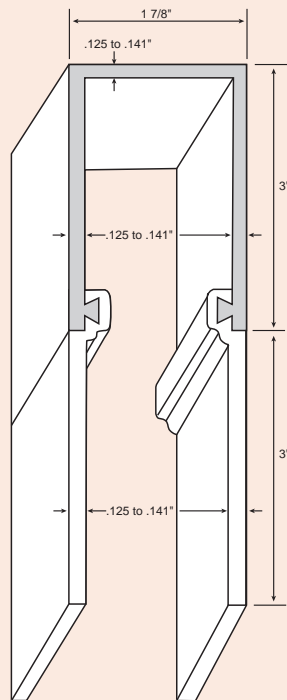


3

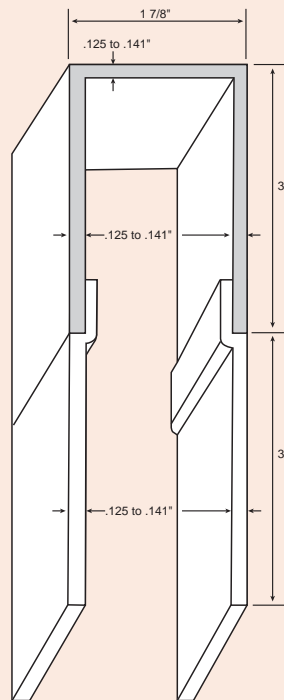
- 1 Impractical. The length of the tongue, 1", is longer than its width, 7/8".
- 2 Practical
- 3 Practical



1



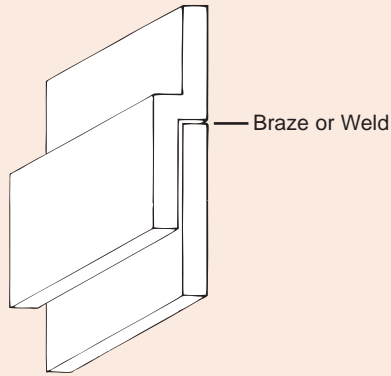
2



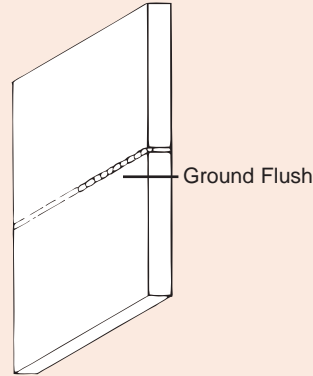
3

- 1 Impractical. The high temperatures of the metal at the time of extrusion will cause the legs to collapse. Due to the depth of the tongue in the die, the material will extrude in a wavy condition.
- 2 More practical, because of the dovetail. The seam is less noticeable than No. 3.
- 3 Another practical way. The seam is more noticeable.

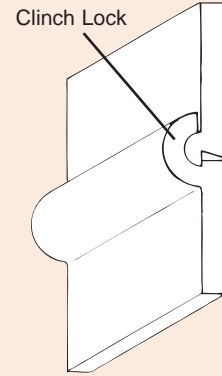
Figure V-6. Joints for Extruded Metals



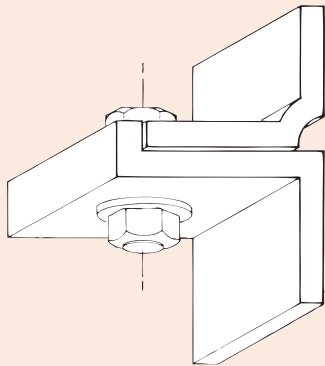
Flush Lap



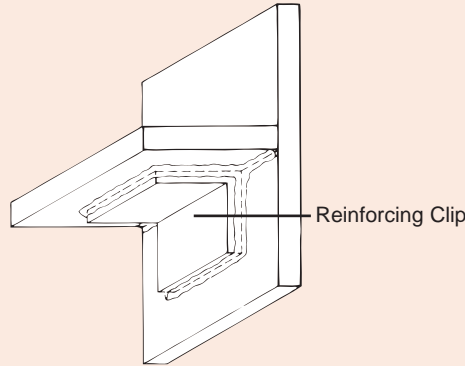
Butt Weld



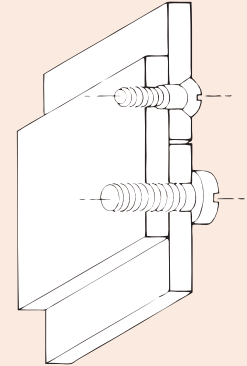
Interlocking



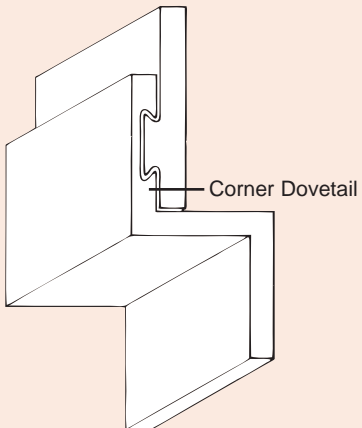
Bolted Flange



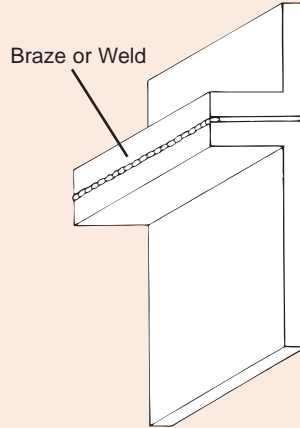
Reinforced Solder



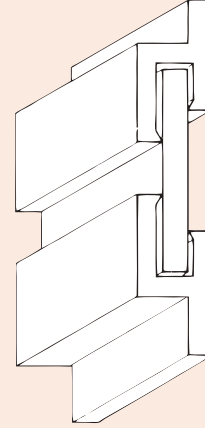
Screw



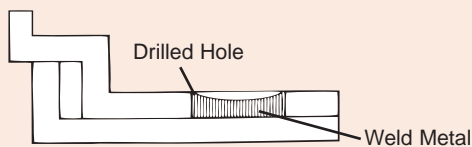
Dovetail



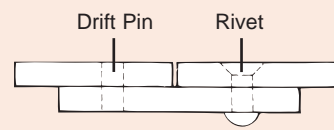
Brazed Flange



Spline



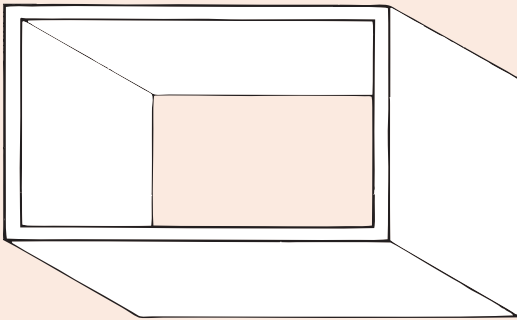
Plug Weld



Pinned or Riveted

Figure V-7. Rectangular, Square and Round Tube

**Rectangular Tube**

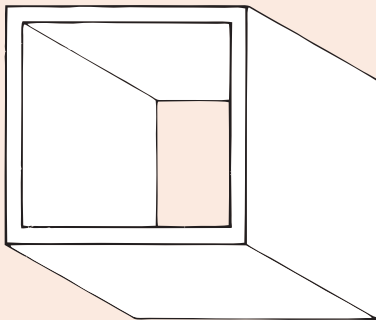


Alloy 230  
Sharp Corners  
16-foot Lengths

**SIZE**

Wall Thickness			Wt, lbs per ft
1"	x 1/2"	x .065"	0.65
1 1/2"	x 3/4"	x .065"	1.02
1 1/2"	x 1"	x .083"	1.50
2"	x 1"	x .083"	1.78
2 1/2"	x 1 1/4"	x .083"	2.15
3"	x 1"	x .065"	1.83
3"	x 1"	x .083"	2.41
3"	x 1 1/4"	x .083"	2.54
3"	x 1 1/2"	x .083"	2.68
3"	x 1 3/4"	x .083"	2.83
3"	x 2"	x .083"	3.05
4"	x 1 3/4"	x .083"	3.46
4 1/2"	x 1 3/4"	x .125"	5.76

**Square Tube**

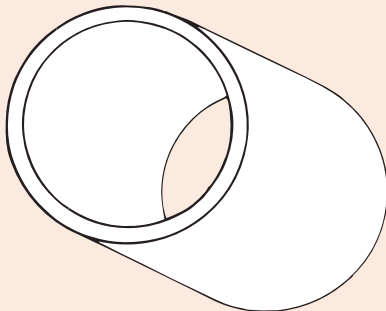


Alloy 230  
Sharp Corners  
16-foot Lengths

**SIZE**

Wall Thickness			Wt, lbs per ft
1/2"	x 1/2"	x .065"	0.43
5/8"	x 5/8"	x .065"	0.55
3/4"	x 3/4"	x .065"	0.68
7/8"	x 7/8"	x .065"	0.76
1"	x 1"	x .065"	0.92
1 1/4"	x 1 1/4"	x .065"	1.13
1 1/4"	x 1 1/4"	x .083"	1.46
1 1/2"	x 1 1/2"	x .083"	1.79
1 3/4"	x 1 3/4"	x .083"	2.07
2"	x 2"	x .083"	2.53
2 1/2"	x 2 1/2"	x .083"	2.99
3"	x 3"	x .102"	4.35

**Round Tube**



Alloy 230  
Standard Pipe Sizes  
20-foot Lengths

Nominal Size	O.D.	Wall Thickness	Wt, lbs per ft
1 1/4"	1.660"	.140"	2.63
1 1/2"	1.900"	.145"	3.13

Unlike red brass pipe, this pipe-size tube is furnished with plain ends, unmarked, and with a smooth finish suitable for polishing.



Round tube is normally shipped in standard 20-ft (6-m) lengths. Pipe is available in copper C12200 and brass C23000 as 12-ft (3.7-m) lengths in standard sizes from 1/8 in to 12 in (3 to 300 mm), both in regular (Schedule 40) and extra strong (Schedule 80) wall thicknesses.

Standard commercial tolerances governing wall thickness, squareness, length and straightness are specified in ASTM B251 - 10 *Standard Specification for General Requirements for Wrought Seamless Copper and Copper-Alloy Tube*; tolerances can be reduced up to one-half at a cost premium. Tube used for railings is supplied to the straightness tolerances listed in **Table 12**. The tolerances govern maximum curvature, unless tighter values are specified. Alternatively, curvature can be reduced through anchorage to closer support spans than those listed in the table.

Permissible corner radii for commercial square tubing are listed in **Table 13**. Sharper corners can be formed by re-drawing to a specified tolerance, normally at a cost premium.

Square and rectangular tubes are supplied to standard twist tolerances as listed in ASTM B251. Twist about the longitudinal axis in a standard tube is limited to one degree per linear foot, measured to the nearest degree. Tighter tolerances can be called out by special order.

### THERMAL EXPANSION AND CONTRACTION

Metals expand when heated and contract when cooled. This thermal movement must be taken into account when designing with copper (and other) metals. Attention is particularly important in roofing and exterior applications, where ambient temperature swings and solar heat gain can have a pronounced effect. That is not to say that thermal effects can be disregarded indoors; provision for movement should always be considered. And, since the amount of expansion and contraction varies for different materials, the relative movement between two (or more) attached elements is important. Avoid using adhesives where there might be any significantly different thermal movement of joined surfaces.

The linear coefficients of thermal expansion among copper alloys may differ by as much as 30 percent. The coefficients apply to both expansion and contraction and are shown as positive or negative numbers, respectively. Coefficients are normally expressed in millionths of an inch of movement per inch of length per degree Fahrenheit of temperature change.

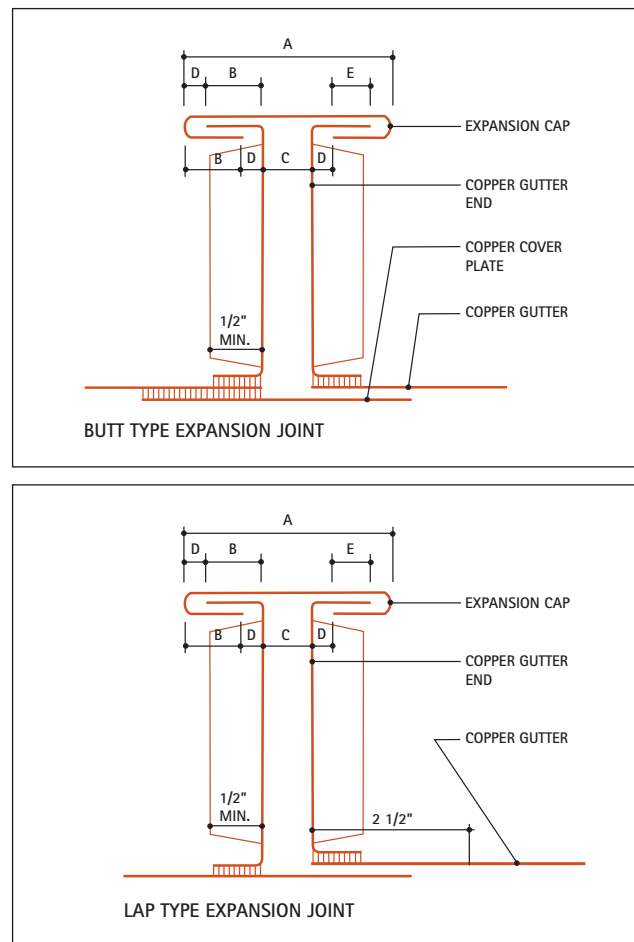
Corresponding SI units are millionths of a centimeter of movement per centimeter of length per Kelvin (or degree Celsius) of change. The change in length in a given length over a given temperature range of material is calculated from the simple expression:

$$\text{Length change} = (\text{Length of architectural element}) \times (\text{Coefficient}) \times (\text{Temperature change in degrees})$$

**Table 14** lists the thermal expansion coefficients for several architectural copper metals and some potentially connected materials. Data for all copper metals can be found at [www.copper.org](http://www.copper.org).<sup>8</sup>

The data show that copper expands and contracts thermally more than carbon steels, that it is similar to 300 series stainless steels, and that it moves considerably less than aluminum.

Expansion and contraction details for copper and copper alloys used in roofing and flashing are documented in the CDA publication, *Copper in Architecture Handbook*, which is available at [www.copper.org/publications](http://www.copper.org/publications).



**Figure V-8.** Typical fabrication details for butt- and lap-type expansion joints for copper gutters. Expansion joints are essential to accommodate thermal expansion and contraction. Consult the *Copper in Architecture Handbook* for detailed information on architectural sheet copper use.

---

## PROTECTION

Despite their durability, copper metals are vulnerable to physical and chemical damage during transport, storage, handling and installation. Field repairs can be costly and time-consuming and may not provide the same high quality of surface finish produced under shop conditions. Appropriate protection should therefore be provided until installation has been completed.



**Figure V-9.** Careful handling, use of gloves and even protective films can potentially protect copper alloy surfaces and may prevent marring or discoloration from skin oils.

The degree of protection depends on the type of installation and the degree of risk. Fabricators are responsible for the quality of the finished installation; therefore, the choice of protective measures is normally (sometimes contractually) left in their hands. Roofing, flashing and wall or column cladding situated in non-traffic areas may not need protection, but damage-prone locations such as metal-clad building entrances and interior doorways may require boarding or physical barriers to prevent damage during construction.

It is important to ensure tradesmen do not inadvertently damage installed copper work. As an example, the acidic fluids used by masons to clean mortar can permanently discolor copper alloys; the metal must be protected from such chemicals.

The simplest and most common protective measures include wiping with oils or waxes (usually removed before service), wrapping in VCI-type paper (Volatile and Vapor Corrosion Inhibiting), and application of strippable paper or plastic films. Sprayed and shrink-wrapped films are also available. A few precautions should be observed:

- Protective media should be free from ammonias, sulfides or other chemicals that may react with and darken many copper alloys.
- Good housekeeping should be observed during wrapping to prevent entrapment of abrasive particles that can scratch finished surfaces.
- Exposure to potentially corrosive atmospheres should be minimized. Chlorides may cause pitting or crevice corrosion under certain conditions. Ammonia and its compounds must be avoided.
- Strippable papers and films should be removed as soon as conditions permit. They should not be exposed to sunlight or excessive heat, since this can make their removal extremely difficult. Partial removal should also be avoided since nonuniform discoloration will result.
- Care should be used in handling to prevent skin oils from tarnishing the metal. Whether or not soft cotton gloves are used, the exposed surfaces should be cleaned following installation with any one of several commercial polishes designed for use on copper alloys. In many cases, such as most exterior architectural applications, tarnishing and fingerprints are unavoidable. Rapid natural weathering usually makes these marks difficult to notice after a few short months.

**Table 1. Compositions, Historic Trade Names, Colors, Properties and Specifications for Selected Copper Alloys<sup>7,8</sup>**

ALLOY FAMILIES	Density	Melting Point:	Temper	Tensile	Yield	Elongation	Modulus of	Coefficient of	Thermal	Electrical	Forms, Specification Standards	
	lb/in <sup>3</sup> (g/cm <sup>3</sup> )	Solidus - S, Liquidus - L °F (°C)		Strength <sup>†</sup> ksi (MPa)	Strength <sup>†</sup> ksi (MPa)	%	Elasticity in Tension ksi (GPa)					Thermal Expansion /°F (68–212°F) (/°C (20–100°C))
COPPERS	<b>C11000*</b> , Electrolytic Tough Pitch, ETP: 99.9% copper (min) Natural: salmon red. Weathered: reddish brown, ultimately to gray-green patina.											
	0.322 (8.91)	1949-S (1065)	1/4 Hard sheet, H00	36 (248)	28 (193)	30	17,000 (117.2)	9.4·10 <sup>-6</sup> (16.9·10 <sup>-6</sup> )	226 (391.1)	101 (5.8·10 <sup>7</sup> )	Building construction sheet, strip: ASTM B370 Bar, Forging: ASTM B124 Tube: ASTM B698, B903 Sheet, Lead Coated: ASTM B101	
			1/4 Hard sheet, H01	38 (262)	30 (207)	35	17,000 (117.2)	9.4·10 <sup>-6</sup> (16.9·10 <sup>-6</sup> )				
	<b>C12200*</b> , Phosphorus Deoxidized, High-Residual Phosphorus, DHP: 99.9% copper (min) Natural: salmon red. Weathered: reddish brown, ultimately to gray-green patina.											
	0.323 (8.94)	1981-L (1083)	1/4 Hard sheet, H00	36 (248)	28 (193)	30	17,000 (117.2)	9.4·10 <sup>-6</sup> (16.9·10 <sup>-6</sup> )	196 (339.2)	85 (4.97·10 <sup>7</sup> )	Building construction sheet, strip: ASTM B370 Strip: ASTM B152, B272 Bar: ASTM B187, B152 Shapes: ASTM B187 Tube: ASTM B698, B903	
			1/4 Hard sheet, H01	38 (262)	30 (207)	25	17,000 (117.2)	9.4·10 <sup>-6</sup> (16.9·10 <sup>-6</sup> )				
<b>C12500*</b> , Fire-Refined Tough Pitch, FRTP: 99.9% copper (min) Natural: salmon red. Weathered: reddish brown, ultimately to gray-green patina.												
0.323 (8.94)	1949-S (1065)	1/4 Hard sheet, H00	36 (248)	28 (193)	30	17,400 (120)	9.3·10 <sup>-6</sup> (16.8·10 <sup>-6</sup> )	202 (349.9)	92 (53.5·10 <sup>7</sup> )	Shapes: ASTM B 216		
		1/4 Hard sheet, H01	40 (276)	28 (193)	28 (193)	17,400 (120)	9.3·10 <sup>-6</sup> (16.8·10 <sup>-6</sup> )					
BRASSES	<b>C22000*</b> , Commercial Bronze, 90%: 90% copper, 10% zinc Natural: red gold. Weathered: brown, ultimately to gray-green patina.											
	0.318 (8.80)	1870-S (1021)	1/2 Hard sheet, H02	52 (359)	45 (310)	110.318 (8.80)	17,000 (117.2)	10.2·10 <sup>-6</sup> (18.4·10 <sup>-6</sup> )	109 (188.7)	44 (2.6·10 <sup>7</sup> )	Plate: ASTM B36 Wire: ASTM B134 Tube: ASTM B135 Sheet: ASTM B36, B694 Strip: ASTM B36, B130, B694	
	<b>C23000*</b> , Red Brass, 85%: 85% copper, 15% zinc Natural: reddish yellow. Weathered: chocolate brown, ultimately to gray-green patina.											
	0.316 (8.75)	1810-S (988)	1/2 Hard sheet, H02	57 (393)	49 (338)	12	17,000 (117.0)	10.4·10 <sup>-6</sup> (18.7·10 <sup>-6</sup> )	92 (159.2)	37 (2.2·10 <sup>7</sup> )	Pipe: ASTM B43 Plate, Bar, Sheet: ASTM B36 Wire: ASTM B134 Tube: ASTM B135 Strip: ASTM B36, B88 Sheet: ASTM B36	
	<b>C26000*</b> , Cartridge Brass, 70%: 70% copper, 30% zinc Natural: yellow. Weathered: yellowish, ultimately to gray-green patina.											
	0.308 (8.53)	1680-S (916)	1/2 Hard sheet, H02	62 (427)	52 (359)	25	16,000 (110.3)	11.1·10 <sup>-6</sup> (20.0·10 <sup>-6</sup> )	70 (121.2)	28 (1.6·10 <sup>7</sup> )	Plate, Bar, Sheet: ASTM B36 Wire: ASTM B134 Tube: ASTM B135 Strip: ASTM B36, B88 Strip: ASTM B19, B36, B569, B888	
	<b>C28000*</b> , Muntz Metal: 60% copper, 40% zinc Natural: reddish yellow. Weathered: red-brown, ultimately to gray-brown patina.											
	0.303 (8.39)	1650-S (899)	1/2 Hard sheet, H02	70 (483)	50 (345)	10	15,000 (103.4)	11.1·10 <sup>-6</sup> (20.8·10 <sup>-6</sup> )	71 (122.9)	28 (1.6·10 <sup>7</sup> )	Plate, Bar, Sheet, Strip: ASTM B36 Tube: ASTM B135	
	<b>C38500</b> , Architectural Bronze, Leaded Brass: 57% copper, 40% zinc, 3% lead Natural: reddish yellow. Weathered: russet brown, ultimately to dark brown patina.											
	0.306 (8.47)	1610-S (877)	1/2 Hard sheet, H02	70 (483)	50 (345)	10	15,000 (103.4)	11.1·10 <sup>-6</sup> (20.8·10 <sup>-6</sup> )	71 (122.9)	28 (1.6·10 <sup>7</sup> )	Plate, Bar, Sheet, Strip: ASTM B36 Tube: ASTM B135 Shapes: B455	
Shapes, M60			60 (414)	20 (138)	30							

Source: CDA

(continued)

Table 1. Compositions, Historic Trade Names, Colors, Properties and Specifications for Selected Copper Alloys

ALLOY FAMILIES	Density lb/in <sup>3</sup> (g/cm <sup>3</sup> )	Melting Point: Solidus - S, Liquidus - L °F (°C)	Temper	Tensile Strength† ksi (MPa)	Yield Strength† ksi (MPa)	Elong- ation† %	Modulus of Elasticity in Tension ksi (GPa)	Coefficient of Thermal Expansion /°F (68–212°F) (/°C (20–100°C))	Thermal Conductivity Btu•ft/ft <sup>2</sup> •hr•°F (Wm•°K)	Electrical Conductivity %IACS (S/m)	Forms, Specification Standards
BRASSES	C46400, Naval Brass, Uninhibited; Tin Brass: 60% copper, 39.2% zinc, 0.7% tin Natural: yellow. Weathered: browns-black, ultimately to gray-green patina.										
	0.304 (8.41)	1630-S (888)	H01 ¼ Hard sheet	70 (483)	58 (400)	17	15,000 (103.4)	11.8•10 <sup>-6</sup> (21.2•10 <sup>-6</sup> )	67 (116.0)	26 (1.5•10 <sup>7</sup> )	Bar, Rod, Shapes: ASTM B21Sheet, Strip: FED QQ-B-63
			¼ hard rod, H01	69 (476)	46 (317)	27					
			M30 Extruded shapes	58 (400)	25 (172)	40					
Hard-drawn (35%) tube, H80			88 607	66 (455)	18						
BRONZES	C51000*, Phosphor Bronze, 5% A: 5% tin, 0.3% zinc, 0.1% iron, Rem. Copper Natural: yellowish red. Weathered: browns, ultimately to gray-green patina.										
	0.320 (8.86)	1750-S (954)	¼ Hard sheet, H01	49 (min) (338)	—	24 (24)	16,000 (110.0)	9.9•10 <sup>-6</sup> (17.8•10 <sup>-6</sup> )	40 (69.2)	15 (0.9•10 <sup>7</sup> )	Bar: ASTM B102, B139 Rod, Shapes: ASTM B139 Sheet: ASTM B103 Strip: ASTM B103, B888
			½ Hard rod, H02	75 (517)	65 (448)	25					
	C65500*, High-Silicon Bronze A: 1.5% zinc, 3.3% silicon, 1.2% manganese, 0.6% nickel, Rem. Copper Natural: reddish old gold. Weathered: russet brown, ultimately to gray-green patina.										
0.308 (8.53)	1780-S (971)	½ Hard wire, H02	98 (676)	57 (393)	8	17,000 (117.2)	10.0•10 <sup>-6</sup> (18.0•10 <sup>-6</sup> )	21 (36.3)	7 (0.41•10 <sup>7</sup> )	Wire: ASTM B99, B105 Tube: ASTM B315 Bar, Shapes: ASTM B98 Sheet, Strip, Plate: ASTM B96	
		½ Hard sheet, H02	78 (538)	45 (310)	17						
		½ Hard rod, H02	78 (538)	45 (310)	35						
		Hard-drawn tube, H80	93 (641)	—	75						
CU NICKELS	C70600*, Copper Nickel, 10%; Copper Nickel 90-10: 88.6% copper, 10.6% Nickel, 1.4% iron Natural: pinkish gray. Weathered: slowly to brown-gray.										
	0.323 (8.94)	2010-S (1099)	¼ Hard Sheet, H01, ≤3/8 in	47-55** (min) (324-379)	25-30** (min) (172-207)	10	18,000 (124.0)	9.5•10 <sup>-6</sup> (17.1•10 <sup>-6</sup> )	26 (45.0)	9 (0.53•10 <sup>7</sup> )	Sheet: ASTM B 122, MIL-C-15726F
Full-hard sheet, H04, ≤3/8 in			60† (414)	38 (262)	10						
NICKEL SILVER	C74500, Nickel Silver, 65-10; White Bronze; German Silver: 65% copper, 25% zinc, 10% nickel Natural: warm silver. Weathered: gray-brown, ultimately to finely mottled gray-green patina.										
	0.314 (8.69)	1960-S (1071)	⅛ Hard sheet, H00	60 (414)	35 (241)	34	17,500 (120.7)	9.1•10 <sup>-6</sup> (16.4•10 <sup>-6</sup> )	26 (45.0)	9 (0.53•10 <sup>7</sup> )	Bar: ASTM B122, B151 Plate: ASTM B122 Rod: ASTM B151 Sheet, Strip: ASTM B122 Wire: ASTM B206
			C75200*, Nickel Silver, 65-18; White Bronze; German Silver: 65% copper, 18% nickel, 17% zinc Natural: warm silver. Weathered: gray-brown, ultimately to finely mottled gray-green patina.								
	0.316 (8.75)	1960-S (1071)	¼ Hard sheet, H01	65 (448)	50 (345)	20	17,500 (121.0)	9.1•10 <sup>-6</sup> (16.4•10 <sup>-6</sup> )	19 (33.0)	6 (0.35•10 <sup>7</sup> )	Bar: ASTM B122, B151 Sheet, Strip: ASTM B122
C79600, Leaded Nickel Silver, 10%; White Bronze; German Silver: 45% copper, 42% zinc, 10% nickel, 2% manganese, 1% lead Natural: warm silver. Weathered: gray-brown, ultimately to finely mottled gray-green patina.											
0.300 (8.39)	1700-S (927)	Full hard rod, H04	70 (480)	40 (273)	15	16,000 (110.0)	11.0•10 <sup>-6</sup> (19.0•10 <sup>-6</sup> )	21 (36.0)	7 (0.40•10 <sup>7</sup> )	None applicable	

(\*) Registered with the U.S. Environmental Protection Agency as an Antimicrobial Copper Alloy.

Source: CDA

(\*\*) Lower values for sheet &gt;24 in wide; higher value for sheet &lt;24 in wide, per MIL-C 15726F.

(†) Tensile properties are typical, unless otherwise indicated.

**Table 2. Tensile and Yield Strengths of Cold-rolled Copper by Temper, ASTM B370**

Temper Designation Standard	Tensile Strength, ksi (MPa), min*		Yield Strength ksi (MPa), min*
	Min.	Max.	
O60, Soft	30 (207)	38 (262)	--
H00, Cold-rolled, 1/8 Hard	32 (220)	40 (276)	20 (138)
H01, Cold-rolled, high yield 1/4 Hard	34 (234)	42 (290)	28 (193)
H02, 1/2 Hard	37 (255)	46 (317)	30 (207)
H03, 3/4 Hard	41 (283)	50 (345)	32 (220)
H04, Hard	43 (296)	52 (359)	35 (241)

Source: ASTM International

(\*) in-lb-ft units are standard in ASTM B370; metric units are included for convenience.

**Table 3. Examples of Temper Designations for Copper Alloys, ASTM B601**

Temper Designation	Temper Name or Condition
<b>Annealed Conditions</b>	
O10	Cast and Annealed
O20	Hot Forged and Annealed
O60	Soft Annealed
O61	Annealed
O81	Annealed to Temper: 1/4 Hard
OS015	Average Grain Size: 0.015 mm
<b>Cold Worked Tempers</b>	
H00	1/8 Hard
H01	1/4 Hard
H02	1/2 Hard
H04	Hard
H06	Extra Hard
H08	Spring
<b>Cold Worked and Stress Relieved Tempers</b>	
HR01	H01 and Stress Relieved
HR04	H04 and Stress Relieved
<b>Precipitation Hardened Tempers</b>	
TB00	Solution Heat Treated
TF00	TB00 and Age Hardened
TH02	TB00 and Cold Worked, and Aged
TM00/TM02/TM08	Mill Hardened Tempers
<b>Manufactured Tempers</b>	
M01	As Sand Cast
M04	As Pressure Die Cast
M06	As Investment Cast

Source: ASTM International

**Table 4. Typical Tensile Properties of Selected Commercial Copper Alloys in Various Tempers Compared with Steels and Aluminum**

Alloy No. Temper	Nominal Zinc Content, Wt%	Tensile Strength, ksi (MPa)	0.2% Yield Strength, ksi (MPa)	Elongation in 2.0 in, %
<b>C11000 Copper</b> OS025 Annealed H02 (Half Hard) H06 (Extra Hard)*	0	34 (235) 42 (283) 52 (358)	11 (76) 36 (255) 47 (324)	45 14 5
<b>C26000 Brass</b> OS015 Annealed H02 (Half Hard) H06 (Extra Hard)*	30	53 (365) 62 (427) 86 (607)	22 (150) 52 (352) 65 (448)	54 25 5
<b>C28000 Muntz Metal</b> M20 As hot-rolled H02 (Half Hard)	40	54 (372) 70 (483)	21 (145) 50 (345)	45 10
<b>C51000 Phosphor Bronze</b> OS025 Annealed HR02 (Half Hard & Stress Relieved) HR06 (Extra Hard & Stress Relieved)	0.30	50 (345) 66 (455) 96 (662)	21 (145) 58 (400) 86 (593)	52 28 11
<b>C70600 Copper Nickel</b> OS050 Annealed H02 (Half Hard) H06 (Extra Hard)*	1.0	51 (350) 68 (469) 79 (545)	13 (90) 63 (434) 76 (525)	35 8 4
<b>C75200 Nickel Silver</b> OS035 Annealed H02 (Half Hard) H04 (Hard)	17	58 (400) 74 (510) 85 (614)	25 (170) 62 (427) 74 (572)	40 8 3
<b>1008 Low-Carbon Steel</b> Annealed Hard	---	44 (303) 70 (483)	25 (170) 60 (413)	41 18
<b>S30400 Stainless Steel</b> Annealed ½ Hard	---	87 (600) typ. 158 (1089) typ.	36 (245) typ. 135 (931) typ.	52 7
<b>3004 Aluminum</b> Soft H38	0.25	26 (180) 41 (285)	10 (69) 36 (250)	20 5

(\*) Nominally, Cold-rolled 50%.

Source: CDA; ASM Handbook, 10th Ed., Vols. 1 and 2

**Table 5. Typical Dimensions of Copper Sheet and Strip**

	Weight per sq ft, ounces	Width, inches	Length, inches
<b>Sheet Copper</b>	12	30, 36	96, 120
	16	30, 36, 48	96, 120
	20	30, 36, 48	96, 120
	24	30, 36	96, 120
	32	30, 36	96, 120
	48	30, 36	96, 120
<b>Strip Copper</b>	16	10, 12, 14, 15, 16, 18, 20, 24	96, 120
	20	20, 24	96, 120
	24	20, 24	96, 120
	32	20, 24	96, 120

Source: CDA

**Table 6. Comparison between Brown Et Sharp (B&S) and U.S. Standard Gauge (USSG) for Sheet Metals**

oz/sq ft (copper)	Nearest B&S Gauge (nonferrous metals)	Nominal B&S Thickness, in (mm)*	Nearest USSG (steels)	USSG Thickness, in (mm)*
6	32	0.0081 (0.0205)	34	0.0086 (0.218)
8	29	0.0108 (0.0274)	31	0.0109 (0.278)
10	27	0.0135 (0.343)	29	0.0141 (0.357)
12	26	0.0162 (0.411)	27	0.0172 (0.437)
16	23	0.0216 (0.549)	25	0.0219 (0.556)
20	21	0.0270 (0.686)	23	0.0281 (0.714)
24	20	0.0323 (0.820)	21	0.0344 (0.873)
32	17	0.0431 (1.090)	19	0.0438 (1.110)
48	14	0.0646 (1.640)	16	0.0625 (1.590)

(\*) Rounded to three significant figures

Source: CDA

**Table 7. Color Matches with Various Fixture Forms of Compatible Copper Alloys\***

Color (unweathered)	Sheet & Plate Alloys	Extrusions	Castings	Fasteners**	Tube & Pipe	Rod & Wire	Filler Metals
Copper-Red	C11000 C12200 C12500	C11000 C12500	Copper (99.9% min)	C11000 C65100	C12200	C11000 C12500	C18900
Bronze-Gold	C22000	C81400	C83400	C65100	C22000	C22000	C65500
Tan-Gold	C23000	C38500	C83600	C28000 C65100	C23000	C23000	C65500
Yellow-Gold	C26000	C26000	C85200 C85300	C26000 C36000 C46400 C46500 C48600	C26000	C26000	C68100
Reddish Yellow	C28000	C38500	C85500 C85700	C28000 C65100	C23000	C28000	C68100
Reddish Old Gold	C65500	C65500	C87500	C65100 C65500	C65100 C65500	C65100 C65500	C65500
Pinkish Gray	C70600	C70600	C96200	C70600	C70600	C70600	C70600
Warm Silver	C74500 C75200	C79600	C97300	C74500	C74500 C75200	C74500 C75200	C77300

(\*) Other matches are possible via chemical weathering.

(\*\*) See **Table 8** for further detail.

Source: CDA

**Table 8. Characteristics of Common Fastener Alloys**

<b>Fastener Alloy</b>	<b>Characteristics*</b>
C11000, Copper, ETP C12200, Phosphorus-Deoxidized, High Residual P, DHP	Used for nails and rivets, most commonly for copper roofing, flashing, wall cladding and other sheet copper installations.
C26000 Cartridge Brass, 70%	Used for full range of medium strength, cold-headed, roll threaded (coarse thread) screws, bolts and nuts. Color matches Cartridge Brass sheet, tube and rod.
C28000 Muntz Metal, 60%	Used for screws, nuts and bolts of relatively low strength, where color match is critical. Excellent color match to Architectural Bronze, C38500.
C36000 Free-Cutting Brass	Used for full range of medium to low strength machine screws, bolts and nuts. Good color match with Cartridge Brass, C26000, C28000 and C38500.
C46400 through C46700 Naval Brasses	Used for full range of medium strength screws, bolts and nuts. Fair to good color match; slightly yellower than Architectural Bronze, C38500.
C48600 Naval Brass, High Leaded	Used for machine screws, bolts and nuts of medium to low strength. Color is yellow. Color match to Muntz Metal (C28000) and Architectural Bronze (C38500) is fair to good.
C65100, Low Silicon Bronze C65500, High Silicon Bronze	Used for full range of medium to high strength nails, screws, bolts and nuts, where color match is not critical. Color is redder than that of Architectural Bronze, C38500. Chemical methods are available for close color matching to many alloys.
C74500 Nickel Silver, 65-10	Used for full range of medium to high strength, cold headed, roll threaded (coarse thread) screws, bolts and nuts. Whitish color matches nickel silver C74500 sheet, tube and rod as well as Leaded nickel silver (C79600) extrusions.
<b>Copper metals may also be joined to other metals using the following fasteners</b>	
Other Metals	Acceptable Fastener Material
Stainless steel	Stainless steel, Copper alloy
Carbon Steel	Metallic coated carbon steel (e.g., galvanized), Copper alloy
Aluminum	Nonmagnetic (austenitic, 300 series) stainless steel

(\*) See also: **Table 7. Color-matched Copper Alloys.**

Source: CDA



**Table 9. Metallurgical Joining Processes and Their Uses\***

Process	Application
<b>Soldering:</b> A relatively low-temperature and low-strength joining process in which filler metals melt between about 350°F and 800°F (177°C and 427°C), considerably lower than the melting point of copper-base metals. The filler metal is drawn between the adjacent metals by capillary action. Lead-free solders are also available.	Widely used for sealing joints, especially with sheet copper, such as for roofing, flashing and gutter work. In order to ensure adequate strength, soldered joints are often reinforced mechanically using clinch locks, rivets or screws.
<b>Brazing:</b> An intermediate-temperature, intermediate-strength joining process using nonferrous filler metals with a melting point between 1100°F and 1500°F (593°C and 816°C), generally lower than the base copper metals. As with soldering, the filler metal is drawn between the adjacent metals by capillary action.	Brazing is often the preferred metallurgical joining method for architectural copper alloys when joint strength and soundness are critical. Since the base metal does not melt, distortion can be minimized through proper fit-up and the use of jigs and fixtures. Care should be taken not to anneal the base metal.
<b>Welding:</b> A high-temperature and/or pressure joining process involving fusion of the base metal with or without the addition of filler metal.	An increasingly popular joining method; however, care should be taken with exposed joints, because color matching is often difficult to achieve and because of the risk of distortion. Large or thick section sizes require preheating before welding to ensure complete fusion.

(\*) See **Metallurgical Joining Processes**, page 18.

Source: CDA

**Table 10. Suitability of Copper Metals for Metallurgical Joining Processes**

Alloy Process	C11000	C12200	C12500	C22000	C23000	C26000	C28000	C38500	C65100	C65500	C70600	C74500	C79600
	Soldering	E	E	E	E	E	E	E	E	E	G	E	E
Brazing	G	E	E	E	E	E	E	G	E	E	E	E	G
Welding													
<i>Oxy fuel</i>	NR	G	G	G	G	G	G	NR	G	G	F	G	NR
<i>GMAW/GTAW*</i>	F	E	E	E	E	E	E	NR	E	E	E	F	NR
<i>SMAW**</i>	NR	NR	NR	NR	NR	NR	NR	NR	F	F	E	NR	NR
<i>Spot Resistance</i>	NR	NR	NR	NR	F	G	G	NR	E	E	G	G	NR
<i>Seam Resistance</i>	NR	NR	NR	NR	NR	NR	NR	NR	G	E	G	F	NR
<i>Butt Resistance</i>	G	G	G	G	G	G	G	F	E	E	E	G	F

Source: CDA

(\*) GMAW=Gas Metal Arc Welding, GTAW=Gas Tungsten Arc Welding or TIG (Tungsten Inert Gas Welding); GMAW and GTAW are two types of Gas Shielded-Arc Welding.

(\*\*) SMAW=Shielded Metal Arc Welding or Coated Metal Arc Welding.

Note: E=Excellent, G=Good, F=Fair, NR= Not Recommended

**Table 11. Minimum Web Thicknesses Based on Overall Extrusion Cross-sectional Size**

Diameter of Circumscribing Circle, in (mm)	Minimum Web Gauge, in (mm)
2 (51)	0.064 (1.60)
3 (76)	0.080 (2.03)
4 (102)	0.093 (2.36)
5 (127)	0.108 (2.74)
6 (152)	0.125 (3.18)

Source: CDA

**Table 12. Straightness Tolerances for Copper Tube, ASTM B251**

Length, ft (m)	Maximum Curvature, in (mm)
3 to 6 (0.9 to 1.8)	3/16 (4.76)
6 to 8 (1.8 to 2.4)	5/16 (7.94)
8 to 10 (2.4 to 3.0)	½ (12.7)
More than 10 ft (3.0 m)	½ (12.7) in any 10-ft (3-m) length

Source: ASTM International

**Table 13. Permissible Corner Radii for Commercial Square Tubing, ASTM B251**

Wall Thickness, in (mm)	Maximum Radius of Outside Corner, in (mm)
Up to 0.058 (1.47)	3/64 (1.19)
0.058 to 0.120 (0.147 to 3.05)	1/16 (1.60)
0.120 to 0.250 (3.05 to 6.35)	3/32 (2.38)

Source: ASTM International

**Table 14. Thermal Expansion/Contraction Coefficients for Selected Copper Metals\***

Copper Metal	Expansion/ Contraction (in/in/°F)x10 <sup>6</sup>	Inches in 10 ft for 100°F rise	Expansion/ Contraction (cm/cm/K)x10 <sup>6</sup>	Centimeters in 3 m for 50°C rise
C11000, C12200	9.4	0.113	16.9	0.254
C26000	11.1	0.133	20.0	0.300
C38500, C28000	11.6	0.139	20.9	0.314
C65500, C83600	10.0	0.120	18.0	0.270
C87300	11.0	0.132	16.8	0.252
Carbon Steel	7.3	0.088	13.0	0.195
Stainless Steel (Type 304)	9.6	0.115	16.2	0.243
Aluminum	12.3	0.148	22.2	0.333
Wood, parallel to grain**	1.7–2.5	0.020–0.030	3.1–4.5	0.047–0.068

Source: CDA

(\*) See **Table 6** for data on additional alloys.

(\*\*) Values are for dried wood. Cross-grain values can be five to ten times the parallel values. Moisture content has a large influence.

**Table 15. BHMA and U.S. Finishes for Brass and Bronze Hardware**

BHMA Code No.	Description	Nearest US Equivalent
605	Bright brass, clear coated	US3
606	Satin brass, clear coated	US4
611	Bright bronze, clear coated	US9
612	Satin bronze, clear coated	US10
613	Dark oxidized satin bronze, oil rubbed	US10B
622	Flat black coated	US19
623	Light oxidized statuary bronze, clear coated	US20
624	Dark oxidized statuary bronze, clear coated	US20A
625	Bright chromium plated over nickel	US26
626	Satin chromium plated over nickel	US26D
632	Bright brass plated, clear coated	US3

**Table 16. Standard Designations for Mechanical Finishes<sup>9</sup>**

Type of Finish	Designation	Description	Examples of Method of Finishing
As-fabricated	M10	Unspecified	Optional with finisher.
	M11	Specular as fabricated	Cold rolling with polished steel rolls.
	M12	Matte finish as fabricated	Cold rolling followed by annealing; also: hot rolling, extruding, casting.
	M1x	Other	To be specified
Buffed	M20	Unspecified	Optional with finisher
	M21	Smooth specular	Cutting with aluminum oxide or silicon carbide compounds, starting with relatively coarse grits and finishing with 320 grit using peripheral wheel speed of 6,000 ft/min (30 m/s). Followed by buffing with aluminum oxide buffing compounds with peripheral wheel speed of 7,000 ft/min (36 m/s)
	M22	Specular	Cutting with compounds as for M21 finish, followed by a final light buffing.
	M2x	Other	To be specified.
Directionally Textured	M30	Unspecified	Optional with finisher.
	M31	Fine satin	Wheel or belt polishing with aluminum oxide or silicon carbide abrasives of 240–320 grit using a peripheral speed of 6,000 ft/min (30 m/s).
	M32	Medium satin	Wheel or belt polishing with aluminum oxide or silicon carbide abrasives of 180–240 grit using a peripheral speed of 6,000 ft/min (30 m/s).
	M33	Coarse satin	Wheel or belt polishing with aluminum oxide or silicon carbide abrasives of 120–180 grit using a peripheral speed of 6,000 ft/min (30 m/s).
	M34	Hand rubbed	Hand rubbing with stainless steel wool and solvent, #0 pumice and solvent, nonabrasive mesh pad or Turkish oil and emery.
	M35	Brushed	Brushing with rotary stainless steel, brass or nickel silver wire wheel. Coarseness of finish controlled by diameter and speed of wheel and pressure exerted.
	M36	(Number unassigned)	
	M3x	(Number unassigned)	To be specified.
Non-directionally Textured	M40	Unspecified	Optional with finisher.
	M41	(Number unassigned)	
	M42	Fine matte	Air blast with #100–#200 mesh silica sand or aluminum oxide. Air pressure 30–90 psi (207–621 kPa). Gun 12 in (305 mm) away from work at an angle of 60–90 degrees.
	M43	Medium matte	Air blast with #40–#80 mesh silica sand or aluminum oxide. Air pressure 30–90 psi (207–621 kPa). Gun 12 in (305 mm) away from work at an angle of 60–90 degrees.
	M44	Coarse matte	Air blast with #20 mesh silica sand or aluminum oxide. Air pressure 30–90 psi (207–621 kPa). Gun 12 in (305 mm) away from work at an angle of 60–90 degrees.
	M45	Fine shot blast	Air blast with S-70 metal shot.
	M46	Medium shot blast	Air blast with S-230 metal shot.
	M47	Coarse shot blast	Air blast with S-550 metal shot.
	M4x	Other	To be specified.

**Table 17. Standard Designations for Chemical Finishes<sup>9</sup>**

Type of Finish	Designation	Description	Examples of Method of Finishing
Non-etched Cleaned	C10	Unspecified	Optional with finisher.
	C11	Degreased	Treatment with organic solvent.
	C12	Chemically cleaned	Use of inhibited chemical cleaner.
	C1x	Other	To be specified.
Conversion Coatings	C50	Ammonium chloride (patina)	Saturated solution of commercial sal ammoniac, spray or brush applied. Repeated applications are sometimes required.
	C51	Cuprous chloride hydrochloric acid (patina)	In 500 ml of warm water, dissolve 164 g of cuprous chloride crystals, 117 ml hydrochloric acid, 69 ml glacial acetic acid, 80 g ammonium chloride, 11 g arsenic trioxide. Dilute to 1 l. Apply by spray, brush or stippling. Repeated applications are sometimes required. Avoid use of aluminum containers.
	C52	Ammonium sulfide (patina)	Dissolve in 1 l of warm water, 111 g ammonium sulfate, 3.5 g copper sulfate, 1.6 g concentrated ammonia. Spray apply. Six to eight applications may be necessary under high humidity conditions.
	C53	Carbonate (patina)	Various formulations having copper carbonate as the major constituent.
	C54	Oxide (statuary)	Principal formulations utilize aqueous solutions of copper sulfates and copper nitrates at temperatures from 85°C to boiling using immersion periods from 30 sec to 5 min.
	C55	Sulfide (statuary)	Apply 2%–5% aqueous solutions of ammonium sulfide, potassium sulfide or sodium sulfide by swabbing or brushing. Repeated application increases depth of color.
	C56	Selenide (statuary)	Proprietary formulations recommended. The solutions are toxic, and user preparation should be avoided. Follow manufacturers' directions for use without deviation.
	C5x	Other	To be specified.

Source: CDA, NOMMA/NAAMM

**Table 18. Standard Designations for Film Laminated Finishes<sup>9</sup>**

Type of Finish	Designation	Description	Examples of Method of Finishing
Film Laminates	Unspecified	L90	Optional with finisher.
	Polyvinyl Fluoride	L91	A one-mil clear film, adhesive bonded to the metal surface.
	Other	L9x	To be specified.

Source: CDA, NOMMA/NAAMM

---

## VI. FINISHES

---

The wide variety of textures and colors available with copper alloys provide architects with an almost limitless palette of visual effects. In order to systematize this colorful collection and provide a basis for specification, the National Association of Architectural Metal Manufacturers (NAAMM) and the National Ornamental & Miscellaneous Metals Association (NOMMA) describe frequently used finishes in the *Metal Finishes Manual for Architectural and Metal Products*.<sup>9</sup>



**Figure VI-1.** This lobby in Anchorage, Alaska, artfully displays panels of copper alloys using a variety of colorful chemical and mechanical finishes.

Field application is occasionally necessary for colored or oxidized finishes and for items such as large immobile statuary. Choice of work-site is normally reserved for the fabricator with consent of the architect.

There are four recognized classes of finishes for copper alloys: mechanical, chemical, protective coatings and laminated finishes. The following paragraphs, abstracted from the NAAMM/NOMMA *Manual*, describe these and a few other finishes. Use the alpha-numeric codes in **Tables 16, 17** and **18** to specify these finishes.

### MECHANICAL FINISHES

Mechanical finishes are imparted by physical rather than chemical means. As examples, buffing and grinding are mechanical operations; whereas, oxidizing and patinating are chemical in nature.

#### As-fabricated

These finishes are the mechanical surface conditions resulting from primary production processes, e.g., hot and cold rolling, extrusion, drawing and casting. They are the least expensive finishes, and, while they may contain imperfections, they are uniform enough with sheet goods for applications such as roofing and wall cladding. The term "mill finish" is commonly used for an "as fabricated" finish.

As-fabricated finishes can be marred by secondary operations such as bending, milling and welding, in which case, they may require additional finishing operations. They can also vary in appearance, both intentionally and accidentally. Rolled finishes, for example, will replicate the surface of the final roll in the mill, and as-cast surfaces will betray the nature of the foundry method employed. As-fabricated finishes include:

**Unspecified**, which place no preconditions on the as-rolled, -extruded, -drawn or -cast metal. For example, unspecified rolled finishes can range from dull to bright and might contain stains imparted by the residues of rolling oils.

**Specular**, which are bright mirror-like finishes in cold-rolled sheet, strip and plate produced by passing the metal between highly polished steel rolls.

*Chemical, heat-treated and mechanical design on copper.*

**Matte**, dull finishes produced by hot rolling, extruding, casting or cold rolling followed by annealing.



**Figure VI-2.** As natural a look as you can get: unfinished copper cathode, 99.9% pure. Typically shipped as melting stock to mills or foundries, cathodes may also be cast into wire rod, billets, cakes or ingots and alloyed with other metals.

### Polished and Buffed

Produced by sequential grinding, polishing and buffing operations, polished and buffed are extremely smooth and bright. Their relatively high cost reflects the added value of preparation. They are frequently used for hardware and small decorative objects. Their high reflectivity imparts a tendency to reveal even slight distortions and lack of flatness. Polished and buffed finishes on interior surfaces are often protected from tarnishing using lacquers such as those discussed on page 42. The two subclassifications of buffed finishes are:

**Smooth specular**, a very bright, mirror-like surface produced by abrasive belt-grinding followed by polishing with progressively finer abrasives and buffing with extremely fine compounds. This is the most costly mechanical finish applied to copper metals. It is especially important to protect smooth specular finishes during installation because they are challenging to apply or touch-up once installed.

**Specular** is a somewhat less-bright surface. It is also produced by polishing and buffing, but to a lesser extent



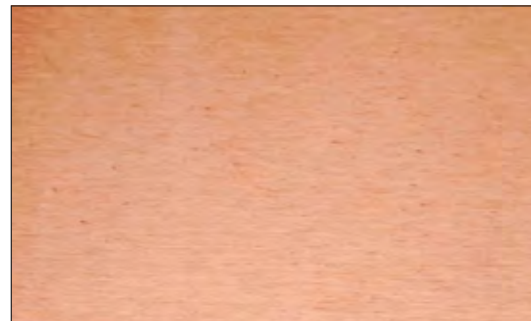
**Figure VI-3.** The specular or mirror finish on this facade reflects the colors and images of its environment.

than that for smooth specular. Surfaces may contain minor scratches and imperfections. Specular finishes are also shop-applied. Field repair is possible but expensive, since it involves extensive hand operations.

### Directionally Textured

These finishes are the most frequently used mechanical treatments for architectural copper metals. Their smooth, satinated appearance is produced by wheel- or belt-polishing with fine abrasives that leave closely spaced, nearly parallel scratches. The six standard directionally textured finishes are:

**Fine, medium and coarse satin**, which reflect the coarseness of the final polishing abrasive. Final grits range from 240 mesh to 320 mesh for fine satin and 80 mesh for coarse satin.



**Figure VI-4.** Directionally textured example: C11000, brush finished.

**Uniform**, a cost-effective finish produced by a single pass of a No. 80 grit belt. Uniform finishes are less expensive than satin finishes and are suitable for many architectural applications.

**Hand-rubbed** finishes are produced by rubbing with No. 0 pumice and solvent on a fine brass wire brush or a woven, nonabrasive pad. This is a relatively expensive, labor-intensive process. It is used where other processes are impractical or where there is a need to smooth and blend other satin finishes.

**Brushed** finishes are produced by power-driven wire-wheel brushes, wire-backed sander heads, abrasive-impregnated fiber pads or abrasive cloth wheels. Scratches produced using brushes are not as uniform as those made with abrasive belts, but brushing offers the advantages that it can be applied to objects with curved or irregular contours. Brushed finishes are difficult to maintain, and their use is normally restricted to small areas or for highlighting.

## Nondirectional Textured

These are matte finishes produced by spraying sand or metal shot against the metal surface. Roughness is controlled by size of sand or shot particles. The process is often used to clean castings and improve appearance of an as-cast surface. Sand blasted surfaces are fairly rough, but smoother finishes can be produced by vapor honing with fine abrasive slurries.

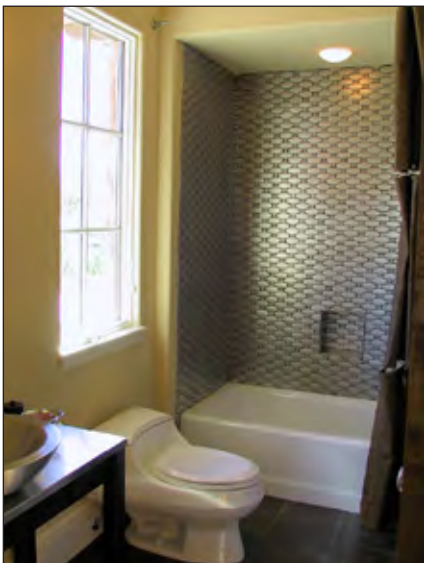
**Hand-applied sand blasted** surfaces have non-uniform textures and are generally not suitable for large areas. Also, the surface deformation caused by blasting leaves residual stresses that can warp thin elements. The process is, therefore, not recommended for flat elements less than 1/4-in (6-mm) thick. Even fine-grit blasted surfaces are rough enough to retain oils and dirt, and will show fingerprints. For an untarnished finish, sand blasted surfaces require protective treatment.

The three grades of fineness for sandblasted surfaces are fine matte, medium matte and coarse matte; produced by appropriately sized silica sand or aluminum oxide. Degrees of grit fineness range from 100–200 mesh for fine textures to 20 mesh for coarse.

**Shot blasted** surfaces are not as rough as sand blasted, but minimum sheet thickness recommendations still apply. Metal shot (usually steel) ranges from S-70 for fine texture to S-550 for coarse. There are three standard grades for shot blasted surfaces: fine, medium and coarse.

## Patterned

Textured, patterned and embossed finishes are produced in light-gauge material by passing sheet between two engraved match-design rolls, impressing patterns on both sides of the sheet (embossing) or between a design roll and a smooth one, thus coining only one side of the sheet. Embossing increases the stiffness of the sheet. It also disperses reflections and minimizes marring in service.

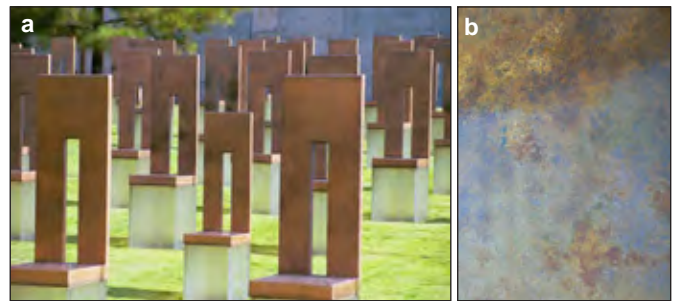


**Figure VI-5.** Complementing or enhancing interior spaces, mechanically finished copper alloy surfaces can take on an infinite array of patterns. Their classy look and durability adds value whether in baths, elevators, lobbies or other locations.

## CHEMICAL FINISHES

Copper alloy surfaces can be chemically altered to produce a wide range of colored finishes. Application is as much a craft as it is a science, and results can vary with such factors as temperature, humidity, surface preparation and skill. Such variability is not necessarily detrimental; it can, in fact, contribute to a finish's charm.

Some chemical treatments are simply for cleaning, as in removing process oils or preparation for subsequent operations. Acid-etching can remove oxides formed during annealing or welding, or to produce a matte surface. "Bright-dip" or "pickled" finishes involve immersing the metal in an acidic bath. They are normally used as intermediate steps before final finishing operations.



**Figure VI-6.** Chemical treatment opens a wide-ranging palette of colors and possibilities: a) artificial finish light bronze on naval brass at the Oklahoma City National Memorial, Oklahoma City, Oklahoma. b) custom chemical treatment of a naval brass panel.

## Conversion Coatings

These comprise the most important class of final chemical finishes. The metal surface is chemically converted to a stable, protective compound, usually an oxide or a sulfide or another compound, to mimic natural weathering. Common conversion coatings include patinas (commonly called "verdegris"), and statuary (oxidized) finishes.<sup>10</sup>

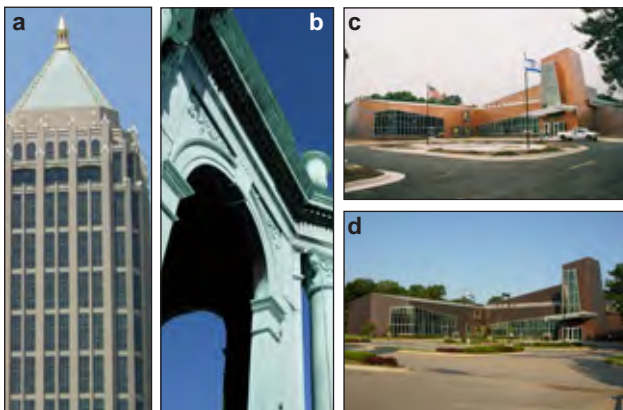


**Figure VI-7.** The oxidized finish on this cast silicon bronze lockset produces a stable compound that inhibits corrosion and maintains its color.



**Patinas** are formed by a variety of methods, all accomplishing in minutes what occurs over years in nature. Synthetic patination replicates the initial period of the natural process to the point where a pleasing color develops. Once placed in service, the natural process continues, reinforcing the applied finish. Early field applied synthetic patination methods yielded coatings that were prone to flaking off, nonuniformity in color and staining of adjacent materials. But, the technology has improved considerably, and modern mill-finished products are more uniform and durable. (See some examples in **Figure 15**, page 45.)

**Natural patinas** are predominantly mixtures of basic copper carbonate and basic copper sulfate (the latter being the mineral, brochantite). However, compositions are variable and depend strongly on the type and concentration of atmospheric constituents. Thus, patinas formed near the sea contain slightly different percentages of copper sulfates, chlorides and carbonates than those formed in industrial or rural areas. Natural patinas are therefore far from uniform, and architects have learned to take this fact into account.



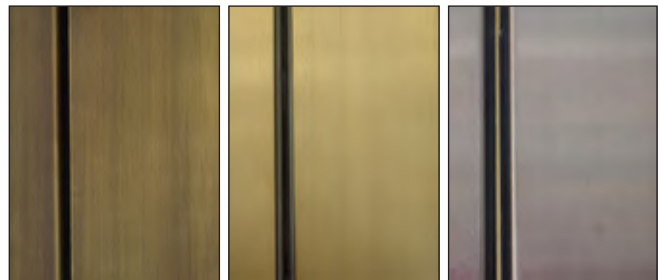
**Figure VI-8.** Natural patinas are seen throughout the world where architects have chosen to use a living metal that projects beauty in any environment and preserves itself for centuries to come. **a)** One Atlantic Center, Atlanta, Georgia; copper roof after more than 20 years' exposure in a humid environment. **b)** Druid Hills Baptist Church, Atlanta, Georgia, mature copper patina, characteristic of over 80 years' exposure in a humid location. **c)** Jewish Federation of Tulsa, Oklahoma, newly installed copper. **d)** Jewish Federation of Tulsa after five years' exposure in a semi-arid climate.

In addition to atmospheric composition, such factors as temperature, humidity, drainage, insolation and roof slope can affect formation rate and appearance. It would not be unusual for the north- and south-facing surfaces of the same roof to patinate differently or at different rates. A synthetic patina can mitigate these effects; although, one that appears too uniform might look contrived until further, natural weathering takes its course.

**Synthetic patinas** are normally produced by the action of acid-chloride or acid-sulfate treatments in which the reagents are applied by brushing, sponging, stippling or spraying. Many patinating processes exist, including proprietary, mill-applied versions applied by sheet and strip suppliers. Patented preparations are also available. When large-area uniformity is not critical, two processes found to be suitable for field- or shop-application are:

*Acid chloride treatments* are based on solutions of sal ammoniac (ammonium chloride) or on cuprous chloride-hydrochloric acid mixtures. Several applications of the sal ammoniac solution may be needed to achieve the desired effect.

*Ammonium sulfate treatment* finishes contain copper sulfate and ammonia. Treatments are applied by spraying and require six to eight applications to achieve the required density.



**Figure VI-9.** Skilful use of chemical treatment techniques provide a great variety of color tones from a given copper alloy.

**Note on chemical weathering in field environments:**

Chemical coloring of exposed flashings, chimney caps and similar small surface areas are possible with reasonable expectation of success. Chemical weathering of large surface areas, such as roofs, spires, domes and walls, is impractical and should be avoided. Realistic color tone, uniformity and durability is difficult to control, and the hand methods employed are expensive. Where large areas are involved, either natural weathering or use of factory patinated copper sheet material provides superior results.

Patinas are normally reserved for non-traffic areas and areas that will receive little or no maintenance. If placed in a traffic area, a clear organic coating may provide protection, but can alter the color.

**Oxide or statuary bronze** treatments are based on cuprous oxide, sometimes combined with a mixture of copper sulfides. They are commonly applied to bronzes used as artistic, decorative or, architectural elements. Their brownish colors range from light to medium to

dark, depending on the copper alloy, fineness of surface texture and concentration and number of applications of coloring solutions. Popular reagents include potassium permanganate and copper salt solutions.

Finishes are often augmented by mechanical abrasion to produce highlights. Statuary finishes are commonly hand-applied and hand-rubbed periodically with wax or oils to maintain a stable appearance.



**Figure VI-10.** Statuary bronze finishes are popular for many uses, including building entries.

**Sulfide treatments** are similar in color to oxide finishes but are produced by dipping, spraying or brushing the surface with reagents such as potassium sulfide, sodium sulfide, ammonium sulfide and, less frequently, antimony pentasulfide, the latter applied as a paste. Oxide treatments may be applied as a preliminary step to improve adherence.

**Selenide treatments** produce deep colors. Formation is rapid with use of appropriate selenide solutions, many of which are proprietary. Application can involve exposure to hazardous reagents.

## PROTECTIVE COATINGS

Coatings are finishes applied over copper metals that may or may not have received mechanical or chemical treatment. Coatings are usually applied for protection but, in some cases, may also provide visual effects.

Coatings take two general forms: *transparent* coatings that preserve natural color, texture and metallic luster of copper metals, and *opaque* coatings that impart corrosion and abrasion resistance while retaining formability.

### Clear Organic Coatings

Copper metals are inherently corrosion-resistant, but thin tarnish films and/or patinas can form over time. Clear organic coatings can retard formation of such films and thus preserve the metals' natural colors by acting as physical and/or chemi-

cal barriers to atmospheric chemicals. These coatings degrade over time, especially in fully exposed exterior applications. When specifying a clear coating, consider effort required to periodically remove the clear coating, refinish the underlying metal and apply a new coating.



**Figure VI-11.** The Anchor Center office building in Scottsdale, Arizona, chose to boast its location in the Copper State by preserving the natural color of freshly milled copper sheet with a clear coating. Due to sun and heat, the finish requires reapplication every few years to maintain its pristine look.

Clear coatings are compounded from synthetic or natural resins, oils or combinations of the three, usually applied as solutions in a volatile solvent. They can be brush- or dip-applied but are most often sprayed and air-dried (*i.e.*, cured or polymerized), especially for large-area applications. They can also be baked, in which case, a harder, more durable (and a more difficult-to-strip) coating results. Finishing processes are straightforward, but any organic coating will perform best when the underlying surface is properly cleaned and prepared as soon as practical before application.

**Inhibited acrylic** coatings include those containing protective chemicals in addition to the base resin(s). INCRALAC®-type coatings are the most effective in this class. Based on acrylic lacquers, INCRALAC coatings contain an organic oxygen scavenger, usually benzotriazole or a related compound. The basic composition was developed by the International Copper Research Association, and a number of licensed commercial versions are available. The coatings are normally sprayed and air-dried, although dipping and baking are also approved. Sprayed and air-dried films are normally specified for exterior uses. Baked films are more abrasion resistant and are preferred for interior applications, although periodic maintenance is required.

Prepare surfaces by washing with a cleaning solvent and, for non-specular finishes, abrasive pads. Avoid steel wool (a general precaution for all copper metals) since it

sometimes contains a rust inhibitor that can stain copper over time if not thoroughly removed. Alkali cleaning is also effective.

**Acrylic coatings** without inhibitors provide good abrasion resistance at somewhat lower cost than inhibited versions. They are useful for both exterior and interior applications where wear and exposure to chemical reagents are design considerations.

**Alkyd coatings** have limited serviceability and tend to yellow outdoors unless modified. They are relatively inexpensive, but must be slow-dried or baked. Exterior performance is improved by compounding with melamine resins. Resistance to chemicals is usually good.

**Cellulose acetate butyrate coatings** are air-drying, inexpensive and, for interior use, provide fair to good service. They tend to darken when exposed to sunlight.

**Epoxy coatings** have excellent resistance to impact, abrasion and many chemicals. They are relatively expensive, and application can involve additional costs in that some compositions are two-part compositions requiring compounding on-site, while other versions require heat curing. Interior performance is exceptional, but coatings may darken and chalk when exposed outdoors.

**Nitrocellulose coatings** are the least expensive, easiest to apply and most common air-drying coatings for mild interior service. Although some of these coatings have limited service life, formulations with alkyd or acrylic resins show improved performance. Exterior use requires stripping and reapplication at approximately yearly intervals depending on exposure conditions. Chemical resistance is low.

**Urethane coatings** have excellent chemical and abrasion resistance. Cost is moderate to relatively high. The coatings were originally intended for interior use, but modified versions may also be suitable for exterior use. Application entails health risks, and appropriate precautions are absolutely necessary.

**Silicone coatings** are also relatively expensive, although they provide the best service at elevated temperatures and under severe exposure conditions. Abrasion resistance is moderate, so a topcoat of a more resistant coating may be needed. When exposed to ultraviolet radiation, silicone coatings may discolor unless the composition includes a suitable inhibitor.

**Pigmented clear coatings**, Pigments are occasionally added to a clear coating to fine tune color match between different alloys.

## Oils and Waxes

These coatings can be applied over most chemical finishes to enhance their appearance with richer luster and greater depth of color. The finishes are almost always applied to statuary bronzes, in which case they also protect the underlying oxide/sulfide surface treatment.

The most common oils are lemon oil (U.S.P.), lemon grass oil (Citrus or East Indian), paraffin oils, linseed oil and castor oil. Popular waxes include carnauba wax and beeswax, either of which can be applied as a mixture with wood turpentine. Quality commercial waxes also give good results.

Oil newly installed metals weekly for the first month to build up a sound base. Apply oils and waxes by hand rubbing with a well-saturated cloth, followed by a second rubbing with a clean cloth to remove excess finish. Application frequency depends on the severity of service: every one or two weeks for heavy traffic areas; monthly for moderate and light duty areas.



**Figure VI-12.** Oil-rubbed bronze gates prepared for installation at the State Capital in Harrisburg, Pennsylvania.

## Vitreous Enamels

These coatings have their place in artwork, decorative objects and some small architectural elements. They are seldom applied to larger architectural works.

## Metallic Coatings

This approach is occasionally used with copper metals, two common examples being tinned and tin-zinc coatings used mainly on copper for roofing, flashing and exterior wall panels. Another example is gilding, whereby a thin layer of gilt (typically gold) is applied to the copper surface.

Other examples include chromium and nickel electroplating given to copper and brass hardware, fasteners and plumbing

goods. Some high-end plumbing fixtures are finished with electroplated gold. Plated layers are normally thin enough to replicate the underlying surface texture.



**Figure VI-13.** Gilded copper dome crowns the Chapel of St. Basil in Houston, Texas; Niko Contracting, sheet metal installer.

### Heat Treatment

This is usually a custom artistic treatment accomplished by gas-torching the metal surface to create patterns of colors. The gas in the torch combines with the air to cause a chemical reaction with the copper alloy surface.

### LAMINATED FINISHES

Laminated finishes are not common for copper metals, since most are opaque. Clear polyvinyl fluoride (PVF) and polyvinylidene fluoride (PVDF) coatings provide corrosion and abrasion resistance and demonstrate long-time resistance to degradation by sunlight.

### STANDARD FINISH DESIGNATIONS

Classification of metal finishes has evolved over the years, but even early systems are still occasionally used. One of these is the U.S. Finishes Designations System, developed by the U.S. Department of Commerce. It mainly defines finishes for brass and bronze hardware. Although it was officially discontinued decades ago, it is still used by some hardware manufacturers and architects today. Ultimately, the Builders Hardware Manufacturers Association (BHMA) established an industrywide numerical system, which is now widely used for hardware items. In deference to common practice, BHMA cross-referenced its designations to the nearest U.S. Finishes numbers, as shown in **Table 15**.

In 1967, the Copper Development Association adopted a system of designations widely used by architects that offers simplicity and uniformity. The system recognizes four most common types of finishes: mechanical, chemical, clear organic





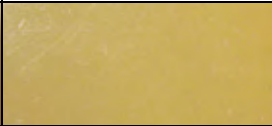









**Figure VI-14.** Heat and chemical treatments applied to a bronze statue by experienced metals restoration firm Stuart Dean.

coatings and laminated coatings, each designated by the letters M, C, O and L, respectively. A specific finish is identified by one of these letters followed by a two-digit number.

**Tables 16, 17 and 18** list specific designations for mechanical, chemical and laminated finishes, respectively. Metal finishing being as much a craft as a technology, the "Examples of Method of Finishing" listed in the tables are merely suggestions and are not to be taken as mandatory. Alternate methods are acceptable in all cases.

Specify finishes by their designation code(s), with preparatory and final steps listed sequentially. Thus, M36-C51 defines a uniform, directionally textured mechanical finish treated with a cuprous chloride-hydrochloric acid conversion coating, in this case a synthetic patina. Specifications need not be that detailed, however, and designers can call out only the final finish, leaving the preparatory operations to the discretion of the fabricator or finisher.

The letter "x" appearing in a designation listed in the tables implies that no number, other than the first digit, has yet been assigned to the finish in question. When such a finish is called out, follow the numerical designation with a brief written explanation.

	<b>C11000 Copper</b>	<b>C23000 Red Brass</b>	<b>C26000 Cartridge Brass</b>
<b>Untreated</b>			
<b>Chemical Weathering</b>			
<b>Sulfide “Statuary” Medium (C-55)</b>			
<b>Sulfide “Statuary” Dark (C-55)</b>			
<b>Patinated (C-52)</b>			

**Figure VI-15.** Chemical weathering may be used creatively to produce different effects or create color matches. The copper alloy, the chemical solution and the application method contribute to the final result.

Source: CDA

---

## VII. MAINTENANCE

---

Copper alloys can be restored to their original appearance, even after years of neglect. Regular attention, however, is the essence of a successful maintenance program. Establish a schedule for periodic cleaning with regular inspections in the interim. The schedule should differentiate between interior and exterior surfaces and surfaces subject to handling, scuffing and abrasion.



**Figure VII-1.** a) Detail of highly weathered copper relief. b) after finish restoration.

Maintenance programs for many alloys include oiling or waxing, reapplication of clear coating, and/or polishing. Restoration of neglected surfaces may require the advice of a specialist.



**Figure VII-2** To preserve a pristine look in high traffic areas, regular maintenance is a must. Professional metal finishing firms specialize in this type of work.

---

## PATINAS

These finishes, by their nature, result from weathering. Since this was the original objective, no maintenance is required and none should be undertaken. The weathered colors and other characteristics of the principal architectural copper alloys are described in **Table 1** and illustrated in **Figure III-7**, page 13.

## CLEAR COATINGS

Most clear, air-dry coatings are readily stripped by dissolving with solvents. Recoating in the field is usually accomplished with the same clear coating. Chemically cured or baked clear coatings should be removed and reapplied under shop conditions. In order to assure a clean, uniform surface prior to reapplication of a clear coating, either in the field or in the shop, a 3% to 5% solution of oxalic acid and water, thickened by adding fine pumice to form a slurry, can remove tar-nish. Standard metal polishes designed for copper or brass materials may prove satisfactory. Remove all pumice or polish residues, especially in crevice areas, before recoating.

## STATUARY FINISHES

Surfaces prefinished or naturally weathered to statuary bronze shades are maintained by periodically reapplying the same oil or wax initially used.

Oil and wax coatings look their best when applied with a well-impregnated, clean, soft cloth followed by rubbing with a second clean, soft cloth to remove excess oil and wax. Frequency of oiling or waxing is as important as the oil or wax used. Newly installed metal should be oiled weekly for the first month in order to build up a protective film.

Metals subjected to heavy traffic should be oiled or waxed at one- to two-week intervals. These areas typically include building entrances, door handles, push plates or bars, and kick plates, as well as door stiles and rails. Where traffic is moderate to light, monthly treatment may suffice. Door frames and adjacent window wall framing usually receive less handling and qualify as moderate to light traffic areas. In non-traffic areas, quarterly or semiannual applications are feasible. Transoms, canopies and similar metal elements normally out of reach are often classed non-traffic areas.

Oils can enhance appearance of naturally or chemically weathered bronze or brass architectural items while inhibiting patina formation, particularly on copper roofing and fascias. When so used, reduce frequency of oiling to one to three years, depending on prevailing climatic conditions and degree of exposure. In some cases, two thin coats of oil has preserved the statuary finish in excess of ten years.

To restore statuary finishes, surfaces may be cleaned with a 5% oxalic acid and water mixture together with a finely ground India pumice powder. Wipe dry with soft, clean cloths and apply a suitable chemical conversion coating, as described in **Chapter VI**.

Air blasting with abrasive walnut shell processes can remove dirt, grime and corrosion products on outdoor metal sculptures without harm.

## SHINY SURFACES

Surfaces not protected by clear organic coatings are best maintained with regular polishing. Apply metal cleaner or polish with a clean, soft cloth rubbing with the grain. To avoid staining, apply cleaner to a limited area and quickly remove by buffing with a clean, soft cloth. Detailed areas may need a rinse to remove polish residue from remaining in crevices — usually, a damp cloth or sponge with clean water is sufficient. Most polishes are inherently corrosive and, if left on the metal surface, may discolor the finish.

## PAINT REMOVAL

Occasionally, it is necessary to remove paint, tar, sealant or other splatters and smears from a copper surface. This is a challenge, especially if it involves a large surface or a surface with an underlying patina. Removal options include chemical solvents or mechanical abrasives, such as sandpaper or various blasting techniques, or combinations of the two.

Regardless, consider the effects on adjacent material and underlying patina. For example, using abrasives to remove paint splatters could also remove the patina and scratch the underlying copper. That area would then require chemical weathering to blend with the surrounding area, or left to weather naturally. When using chemical methods, determine the suitability of the solvent based on the material to be removed as well as the effect it might have on the underlying metal. Be sure to protect surrounding materials.

## VIII. CONCLUSION

Copper is man's oldest metal, first discovered and used some 10,000 years ago. Together with its nearly 800 alloys, copper has unleashed man's imagination for tools, technology, art and architecture for millennia.

Through this publication, we have attempted to acquaint you with many traditional examples of its architectural use and the unique ways it is being used today. In the process, we've briefed you on its distinctive physical, mechanical and appearance properties, the many methods discovered (so far) to fabricate and manipulate the metal, some insight and tips on designing with this remarkable material, and it's proper installation and maintenance.

Most importantly, we hope you have seen the virtually unlimited possibilities available to architects, interior designers, contractors and manufacturers.

Over the centuries, we see an expanding universe of artistic application that ensure this age old material is still appropriate for both today's and tomorrow's structures.

We invite you to explore the copper metals and savor their durability, diversity and flexibility. They are the most recycled and most eco-friendly of architectural metals. They offer you the opportunity to make a distinctive statement of dedication to the environment, to your art and to your clients.

For architectural design assistance related to copper and copper alloys, please visit [www.copper.org](http://www.copper.org) or contact the staff at the Copper Development Association. We are ready to help in any way we can.

*Rocci double doors (pictured right) cast in silicon bronze.*





---

## ENDNOTES

<sup>1</sup> Laboratory testing shows that, when cleaned regularly, Antimicrobial Copper™ kills greater than 99.9% of the following bacteria within two hours of exposure: MRSA, vancomycin-resistant *Enterococcus faecalis* (VRE), *Staphylococcus aureus*, *Enterobacter aerogenes*, *Pseudomonas aeruginosa*, and *E. coli* O157:H7. Antimicrobial Copper surfaces are a supplement to and not a substitute for standard infection control practices. Like other antimicrobial products, they have been shown to reduce microbial contamination, but do not necessarily prevent cross contamination; users must continue to follow all current infection control practices.

<sup>2</sup> Developed by the U.S. Green Building Council (USGBC), Leadership in Energy and Environmental Design (LEED) is an internationally recognized green building certification system, providing third-party verification that a building or community was designed and built using strategies intended to improve performance in metrics such as energy savings, water efficiency, CO<sub>2</sub> emissions reduction, improved indoor environmental quality, and stewardship of resources and sensitivity to their impacts.

<sup>3</sup> International Standards conversions provided by the Deutsche Kupferinstitut [www.copper-key.org/index.php?lang=english](http://www.copper-key.org/index.php?lang=english)

<sup>4</sup> Detailed, up-to-date information on Antimicrobial Copper Alloys is found at: <http://www.antimicrobialcopper.com/>

<sup>5</sup> Salgado, C., et al. "Copper Surfaces (CuS) Significantly Lower Rate of Hospital Acquired Infections (HAIs) in the Medical Intensive Care Unit (MICU)," IDSA 2011, Abstract 163.

<sup>6</sup> A thorough understanding of the metallurgical joining processes is found in the CDA publication, *Welding Copper and Copper Alloys*, A1050, based on Eighth Edition of *The Welding Handbook of the American Welding Society* (AWS).

<sup>7</sup> Lists of copper suppliers can be found at <http://www.copper.org/resources/suppliers/homepage.html>

<sup>8</sup> [www.copper.org/resources/properties/db/CDAPropertiesSelectionServlet.jsp?mode=basic](http://www.copper.org/resources/properties/db/CDAPropertiesSelectionServlet.jsp?mode=basic)

<sup>9</sup> *NAAMM/NOMMA Metal Finishes Manual*, Chapter 2: "Finishes for the Copper Alloys," National Association of Architectural Metal Manufacturers, AMP 500-06, 2006

<sup>10</sup> See also: *How to Apply Statuary and Patina Finishes*, CDA, A1081, [www.copper.org/publications/pub\\_list/pdf/a1081.pdf](http://www.copper.org/publications/pub_list/pdf/a1081.pdf)

---

# REFERENCES

## CDA Publications

The following publications are available from the Copper Development Association, 260 Madison Ave., New York, NY 10016. A full listing of CDA publications and ordering information may be found at:

[http://www.copper.org/publications/pub\\_list/homepage.html](http://www.copper.org/publications/pub_list/homepage.html)

A4050: *Copper in Architecture – Design Handbook*

A4012: *Copper in Architecture – Roofing Applications*

A4011: *Copper in Architecture – Wall Cladding Applications*

A4094: *Copper Roofs Are Cool*

401/OR: *Sheet Copper Applications*

A1081: *How to Apply Statuary and Patina Finishes*

A1350: *Clear Organic Finishes for Copper and Copper Alloys*

A4082: *The Role of Copper, Bronze and Brass in Architecture & Design*; Reprinted from *Metal Architecture*, May 2007.

A4085: *Adventures in Green Building*; Reprint, *MetalMag Online* (published by R.R. Donnelley), Nov/Dec 2007, pp 60–68.

A4095: *Copper Advantage*; Reprint: *Metal Architecture*, June 2009.

A4085: *Adventures in Green Building*; Reprint, *MetalMag Online* (published by R.R. Donnelley), Nov/Dec 2007, pp 60–68.

A1360: *The Copper Advantage—A Guide to Working With Copper and Copper Alloys*

A1050: *Welding Copper and Copper Alloys*

## Additional Publications

American Society for Materials, *Properties and Selection: Nonferrous Alloys and Special-Purpose Materials*. ASM Handbook, Tenth Ed. Vol. 2, ASM International, Materials Park, Ohio, 1990.

ASTM International, *Copper and Copper Alloys*. Annual Book of ASTM Standards, Vol.2.1 (2), ASTM International, West Conshohocken, Penn., Revised Annually.

Breedis, J.F. & Caron, R.N., "Copper Alloys (Wrought)," *Kirk-Othmer Encyclopedia of Chemical Technology*, Fourth Ed. Vol. 7:429–73, John Wiley & Sons, Inc., Hoboken, N.J., 1993.

Gould, et al., "The antimicrobial properties of copper surfaces against a range of clinically important pathogens." *Annals of Microbiology*. Vol. 59:1, 151–156, 2009.

Mendenhall, J.H., *Understanding Copper Alloys*. Robert E. Krieger Publishing Co., Malabar, Fla., 1986.

National Association of Architectural Metal Manufacturers, *NAAMM/NOMMA Metal Finishes Manual*, Chapter 2: "Finishes for The Copper Alloys," AMP 500-06, 2006.

Salgado, C., et al. "Copper Surfaces (CuS) Significantly Lower Rate of Hospital Acquired Infections (HAIs) in the Medical Intensive Care Unit (MICU)," Abstract 163.

Tyler, D.E., "Wrought copper and copper alloy products." *Properties and Selection: Nonferrous Alloys and Special-Purpose Materials*. ASM Handbook, Tenth Ed. Vol. 2:244, ASM International, Materials Park, Ohio, 1990.

Weaver, L., Michels, H.T., Keevil, C.W., "Potential for preventing spread of fungi in air-conditioning systems constructed using copper instead of aluminum." *Letters in Applied Microbiology*. Sept. 2009.

## Website References

Copper Development Association, Architectural Information, <http://www.copper.org/applications/architecture/homepage.html>

Copper Development Association, Copper Alloy Suppliers, <http://www.copper.org/resources/suppliers/homepage.html>

Copper Development Association, Copper Standards and Specifications, [www.copper.org/resources/standards/homepage.html](http://www.copper.org/resources/standards/homepage.html).

Copper Development Association, Copper & Copper Alloy Corrosion Resistance Database, <http://www.copper.org/resources/properties/db/CDACorrosionSelectionServlet.jsp>.

Canadian Copper and Brass Development Association, Architectural Information, <http://www.coppercanada.ca/architectural.html>.

International Copper Association, Antimicrobial Copper, <http://www.antimicrobialcopper.com/us/contact.aspx>.

*Infection Control Today Magazine*, <http://www.infectioncontrolday.com>.

*Infection Control Today Webinar: Antimicrobial Copper Surfaces – Clinical and Laboratory Performance*, <http://www.infectioncontrolday.com/webinars/2011/07/antimicrobial-copper-surfaces--clinical-and-laboratory-performance.aspx>

Arubis Buffalo, Inc., <http://www.arubis.com/en/corporate-group/group-structure/business-units>.

Chicago Extruded Metals Company, [www.cxm.com](http://www.cxm.com).

Hussey Copper Ltd., [www.husseycopper.com](http://www.husseycopper.com).

Olin Brass, <http://www.olinbrass.com/Pages/default.aspx>.

PMX Industries, Inc., <http://www.ipmx.com>.

Revere Copper Products, Inc., <http://www.reverecopper.com>.

Mac Metals, Inc, <http://www.macmetals.com>.

National Bronze Manufacturing Company, <http://www.nationalbronze.com>.

ASM International, Alloy Center, <http://products.asminternational.org/alloyfinder/index.jsp>,

ASTM International, [www.astm.org](http://www.astm.org).

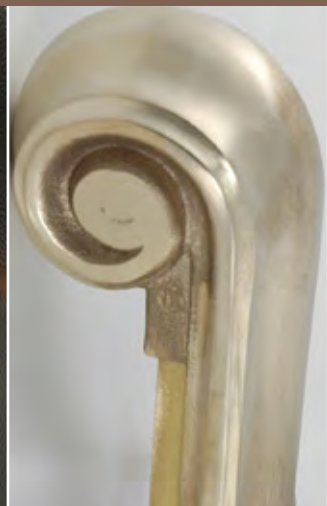
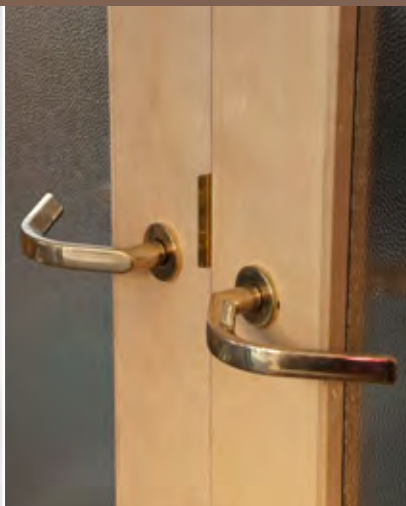
American Welding Society, <http://www.aws.org/w/a>.

National Association of Architectural Metal Manufacturers, <http://www.naamm.org>.

National Ornamental & Miscellaneous Metals Association, <http://www.nomma.org>.

## FIGURE / PHOTO CREDITS

Front Cover (left-right) .....	iStockphoto; CDA; CDA; Northeast Collaborative Architects, LLC
Back Cover (left-right) .....	CDA; CDA; CDA; R & B Wagner, Inc.
I--background.....	Wiemann Metalcraft
I-1 .....	iStockphoto, Jonathan Zander
I-2 .....	CDA
I-3 .....	CDA
I-4 .....	a) CDA; b) CDA; c) Penn State University
II--background .....	CDA
II-1 .....	a) Heather Et Little; b) CDA; c) Niko Contracting; d) Micah Clemens; e) SmithGroup; f) Evelyn Rosenberg; g) CDA
II-2 .....	a) Hans Liebscher; b) Hans Liebscher
II-3 .....	Revere Copper Products
II-4 .....	a) Wiemann Metalcraft; b) CDA; c) Valerius Metalsmithing
II-5a) .....	CDA; b) CDA; c) CDA; d) Lavi Industries; e) Rocky Mountain Hardware
II-6 .....	a) Rocky Mountain Hardware; b) Elkay
II-7 .....	DeAngelis Iron Work
II-8 .....	iStockphoto
III--background .....	CDA
III-1 .....	CDA
III-2 (a-d) .....	CDA
III-3 (a-c) .....	CDA
III-4 .....	CDA
III-5 .....	a) Marlon Blackwell; b) CDA
III-6 .....	a) Mac Metals; b) R & B Wagner, Inc.; c) Wiemann Metalcraft
III-7 .....	CDA
III-8 (a-d) .....	CDA
III-9 .....	Joseph Iano, Fundamentals of Building Construction, 4th Edition
III-10 .....	CDA
IV--background.....	Revere Copper Products
IV-1 .....	iStockphoto
IV-2 .....	Carl J. Petrilli, Architect
IV-3 .....	a) CDA; b) Cotera+Reed Architects
IV-4 .....	CDA
IV-5 .....	a) Mango Copper Industries; b) Kenroy Home
IV-6 .....	a) Wiemann Metalcraft; b) CDA
IV-7 .....	a) Andersen Corporation; b) iStockphoto
IV-8 (a-b) .....	CDA
IV-9 (a-b) .....	H&H Tube Et Manufacturing Company
IV-10 .....	CDA
IV-11 .....	Hammel, Green and Abrahamson, Inc.
IV-12 .....	Evelyn Rosenberg
IV-13 .....	CDA
IV-14 .....	CDA
IV-15 .....	Concord Sheet Metal Products
IV-16 .....	J.T. Cooper Studios
V--background.....	CDA
V-1 (a-d) .....	CDA
V-2 (a-b) .....	National Park Service
V-3 .....	CDA
V-4. a) .....	The Wagner Companies; b) Lavi Industries; c) Julius Blum Et Co, Inc.
V-5 .....	CDA
V-6 .....	CDA
V-7 .....	CDA
V-8 .....	CDA
V-9 .....	HOMETIME
VI--background .....	CDA
VI-1 .....	CDA
VI-2 .....	CDA
VI-3 .....	CDA
VI-4 .....	CDA
VI-5 .....	CDA
VI-6 (a-b) .....	CDA
VI-7 .....	Rocky Mountain Hardware
VI-8 (a-d) .....	CDA
VI-9 .....	Stuart Dean
VI-10 .....	Stuart Dean
VI-11 .....	CDA
VI-12 .....	Wiemann Metalcraft
VI-13 (a-b) .....	CDA
VI-14 .....	Stuart Dean
VI-15 .....	CDA
VII--background .....	Stuart Dean
VII-1 .....	Stuart Dean
VII-2 .....	Stuart Dean
VIII--background .....	Wiemann Metalcraft



Copper Development Association  
260 Madison Avenue  
New York, NY 10016-2401  
[www.copper.org](http://www.copper.org)

Canadian Copper and Brass  
Development Association  
49 The Donway West, Suite 415  
North York, ON M3C 3M9 Canada  
[www.coppercanada.ca](http://www.coppercanada.ca)